



Website: www.rugbymfg.com
E-mail: sales@rugbymfg.com
Phone: 1-800-869-9162

1657499

MODEL LR-26C, LR-623, LR-28A, & LR-2355 SUB-FRAME HOIST INSTALLATION AND OPERATION MANUAL

To Be Filled In By Installer	
Hoist Serial #:	_____
Pump Installation and Operation Manual #:	_____
In Service Date:	_____
Dealer:	_____
Address:	_____
City, State ZIP:	_____
Dealer Phone Number:	_____

Use this manual ONLY if installing or operating a model LR-26C, LR-623, LR-28A, or LR-2355 hoist in a sub-frame. This manual should be kept in the glove compartment of the truck for reference when needed.

Original Revision: January 18, 2007
Current Revision: D August 4, 2020

"HYDRAULIC SYSTEM"

The hydraulic system supplied with a given hoist manufactured by TBEI-Rugby is made up of components (pump, valves, reservoir, hoses, cylinder, etc.) that are designated to be compatible with each other.

WARNING: If you substitute hydraulic components, it is your responsibility to **BE SURE** they are compatible with the other components supplied by TBEI-Rugby. Incompatible hydraulic components may cause failure of the hoist that, in turn, could damage the vehicle, damage other property, and cause human injury or death.

All TBEI-Rugby's liability and warranty for a given hoist will be voided, if it is determined by TBEI-Rugby, that substituted hydraulic components were incompatible with those supplied by TBEI-Rugby.

Several hoist parameters are given in the following table, these parameters are given as a general guide. To ensure component compatibility, consult TBEI-Rugby.

HOIST MODEL	LR-26C LR-623 LR-28A	LR-2355
"MAXIMUM" HYDRAULIC FLOW RATE (GPM)	9 GPM	18 GPM
"MAXIMUM" PRESSURE FOR RAISING PORTION OF DUMP CYCLE (PSI)	3200 PSI	3200 PSI
"MAXIMUM" PRESSURE FOR LOWERING PORTION OF DUMP CYCLE (PSI)	1000 PSI	1000 PSI

WARNING: Adjusting the hydraulic pressure to more than the recommended setting may cause the hoist to fail during the dumping of a load. This could cause damage, serious injury, or death. **Never** adjust the pressure on your own. Consult the manufacturer if the hydraulic pressure is in question. Have only a qualified person set the hydraulic pressure. **Never** adjust the pressure to more than the recommended amount.

NOTE: A manual for the hydraulic system is supplied separate from this manual. Refer to the hydraulic system manual for details on the installation and operation of the hydraulic system.

"WARNINGS"

- WARNING:** Installing or operating this hoist without first understanding the proper installation and operation procedures can lead to serious injury or death. Always read and understand fully all installation and operation manuals before installing or operating this equipment.
- WARNING:** Welding, oxy-fuel cutting, or grinding sparks can cause fuel to ignite that in turn can lead to injury or death. **Always** take adequate steps to avoid ignition of fuel from fuel tanks when welding, grinding, or oxy-fuel cutting during equipment installation.
- WARNING:** Heat from the truck's exhaust system can cause hydraulic component failure and may lead to a fire that could cause injury or death. **Always** install equipment in locations where heat from the exhaust system will not damage any hydraulic component.
- WARNING:** Being under a raised body can result in serious injury or death should the body unexpectedly descend. **Never** position yourself or allow others to position themselves under a **loaded** body. **Always** prop the **unloaded** body up using the body prop or body props supplied. **Remember** body props are to be used only on an **unloaded** body. When two props are provided, both props must be used.
- WARNING:** Malfunctioning equipment can cause property damage, injury or death. **Always** have faulty equipment repaired before continuing its use. Consult the manufacturer if required.
- WARNING:** Overloading of a body can cause vehicle or body component damage or an accident which may cause injury or death. **Never** exceed the gross vehicle weight (GVW) or the gross axle weight (GAW) rating of your vehicle.
- WARNING:** The inadvertent shorting of the vehicle's electrical supply can cause a fire or equipment damage that could lead to injury or death. **Always** disconnect the vehicle battery prior to installing, servicing, or repairing the power unit.
- WARNING:** Damage to brake lines during equipment installation, or installing bolts or equipment in such a way that the line will rub and become damaged can lead to brake failure which can cause an accident and can lead to severe injury or death. **Always** take adequate steps to prevent brake line damage during installation and isolate brake lines from installed equipment.
- WARNING:** Connecting the hoist to a hydraulic system with more pressure (psi) or flow (gpm) than is recommended by the hoist manufacturer can cause the hoist to fail during the dumping of a load. This could lead to damage, serious injury, or death. **Be sure** you have the correct pressure and flow.

TABLE A LR-26C SUB-FRAME APPLICATION CHART

BODY LENGTH	OVERHANG	CAPACITY 47° DUMP ANGLE
10'	12"	18.0 TONS
10'	0"	14.4 TONS
11'	12"	16.0 TONS
11'	0"	13.1 TONS
12'	24"	18.0 TONS
12'	12"	14.4 TONS
12'	0"	12.0 TONS
13'	24"	16.0 TONS
13'	12"	13.1 TONS
13'	0"	11.0 TONS
14'	24"	14.4 TONS
14'	12"	12.0 TONS
14'	0"	10.2 TONS

LR-26C SUB-FRAME DUMP CLASS: 50 8.0" Mounting Height

	STANDARD
DUMP ANGLE	M
47°	90.50"

FIGURE
1A

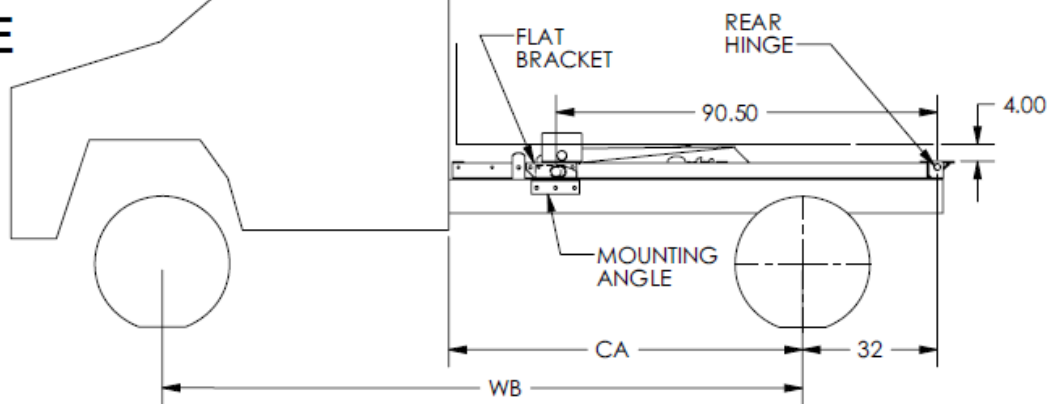

Capacities are based on the following:

1. Water level non-diminishing loads.
2. The hydraulic relief pressure set at the maximum 3,200 psi (see page 2 of this manual).

IMPORTANT: Because of variations in applications, the data contained in this sheet is provided only as a general guide.

TABLE B
LR-623 SUB-FRAME APPLICATION CHART

BODY LENGTH	OVERHANG	CAPACITY 50° DUMP ANGLE
10'	6"	17.8 TONS
12'	6"	14.6 TONS
13'	18"	16.0 TONS
13'	24"	17.8 TONS
13'	42"	26.7 TONS
14'	18"	14.6 TONS
14'	30"	17.8 TONS
14'	36"	20.0 TONS
16'	18"	12.3 TONS
16'	24"	13.3 TONS
16'	42"	17.8 TONS
18'	18"	10.7 TONS
18'	30"	12.3 TONS
18'	42"	14.6 TONS

LR-623 SUB-FRAME
DUMP CLASS: 50
 9.0" Mounting Height

	STANDARD
DUMP ANGLE	M
50°	95.50"

FIGURE 1B

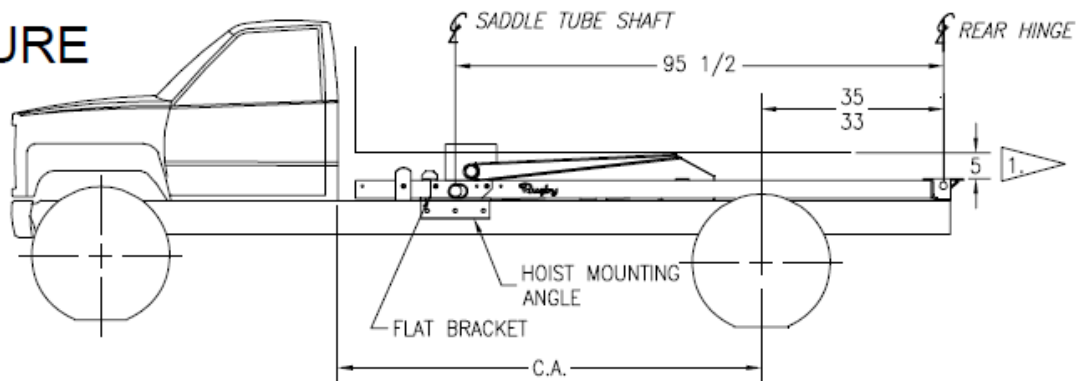

Capacities are based on the following:

1. Water level non-diminishing loads.
2. The hydraulic relief pressure set at the maximum 3,200 psi (see page 2 of this manual).

IMPORTANT: Because of variations in applications, the data contained in this sheet is provided only as a general guide.

TABLE C
LR-28A SUB-FRAME APPLICATION CHART

BODY LENGTH	OVERHANG	CAPACITY 54° DUMP ANGLE
10'	0"	16.8 TONS
11'	12"	18.6 TONS
11'	0"	15.2 TONS
12'	24"	21.0 TONS
12'	12"	16.8 TONS
12'	0"	14.0 TONS
13'	24"	18.6 TONS
13'	12"	15.2 TONS
13'	0"	12.9 TONS
14'	24"	16.8 TONS
14'	12"	14.0 TONS
14'	0"	12.0 TONS

LR-28A SUB-FRAME
DUMP CLASS: 60
 9.0" Mounting Height

	STANDARD
DUMP ANGLE	M
54°	109.81"

**FIGURE
1C**

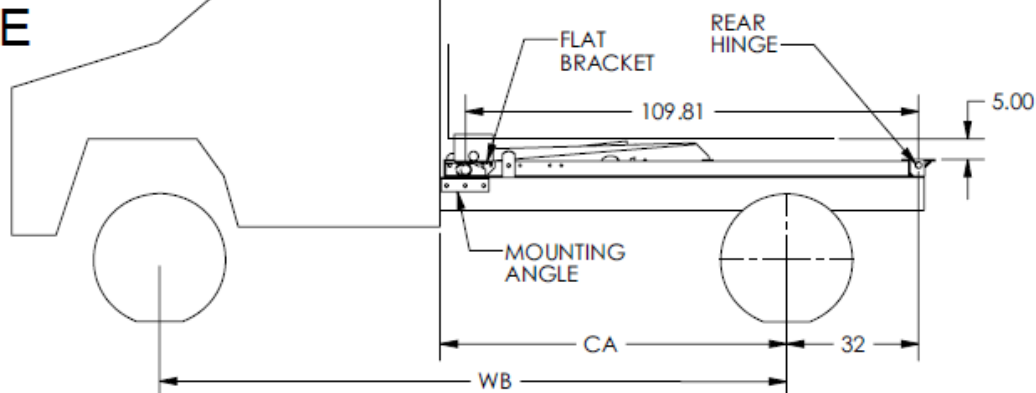

Capacities are based on the following:

1. Water level non-diminishing loads.
2. The hydraulic relief pressure set at the maximum 3,200 psi (see page 2 of this manual).

IMPORTANT: Because of variations in applications, the data contained in this sheet is provided only as a general guide.

TABLE D
LR-2355 SUB-FRAME APPLICATION CHART

BODY LENGTH	OVERHANG	CAPACITY 50° DUMP ANGLE
10'	0"	20.2 TONS
11'	12"	22.5 TONS
11'	0"	18.4 TONS
12'	24"	25.3 TONS
12'	12"	20.2 TONS
12'	0"	16.9 TONS
13'	24"	22.5 TONS
13'	12"	18.4 TONS
13'	0"	15.6 TONS
14'	24"	20.2 TONS
14'	12"	16.9 TONS
14'	0"	14.4 TONS

LR-2355 SUB-FRAME
DUMP CLASS: 60
 9.0" Mounting Height

	STANDARD
DUMP ANGLE	M
50°	95.50"

FIGURE 1D

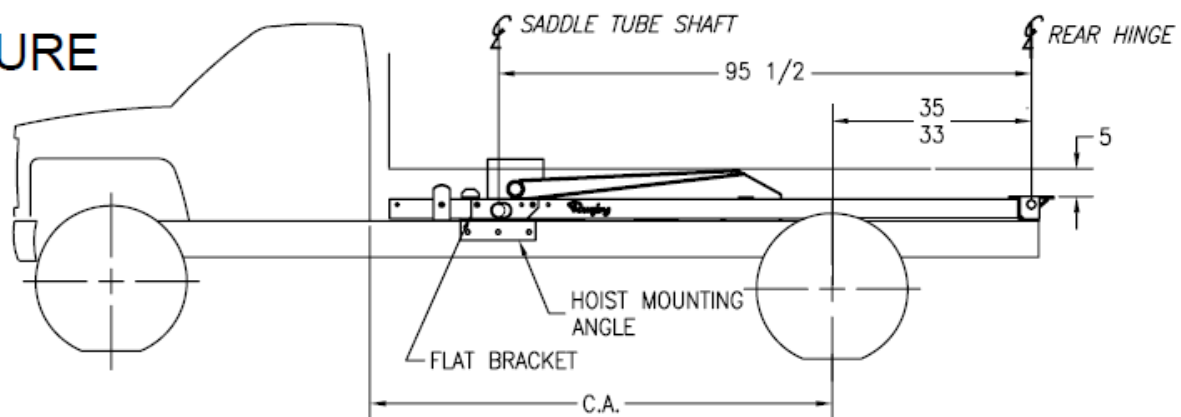

Capacities are based on the following:

1. Water level non-diminishing loads.
2. The hydraulic relief pressure set at the maximum 3,200 psi (see page 2 of this manual).

IMPORTANT: Because of variations in applications, the data contained in this sheet is provided only as a general guide.

"INSTALLATION INSTRUCTIONS"

1. If a LR-26C hoist is to be mounted in this sub-frame, first bolt the two flat brackets to the sub-frame as shown in Figure 1A LR-26C. Next, position the hoist saddle so that it lines up with the flat edge of the flat bracket. This will give a mounting distance of 90.50" from the centerline of the hoist saddle shaft to the centerline of the sub-frame rear hinge.

If a LR-623 or LR-2355 hoist is to be mounted in this sub-frame, first bolt the two flat brackets to the sub-frame as shown in Figure 1B LR-623 or 1D LR-2355. Next, position the hoist saddle so that it lines up with the flat edge of the flat bracket. This will give a mounting distance of 95.50" from the centerline of the hoist saddle shaft to the centerline of the sub-frame rear hinge.

If a LR-28A hoist is to be mounted in this sub-frame, first bolt the two flat brackets to the sub-frame as shown in Figure 1C LR-28A. Next, position the hoist saddle so that it lines up with the flat edge of the flat bracket. This will give a mounting distance of 109.81" from the centerline of the hoist saddle shaft to the centerline of the sub-frame rear hinge.

Ensure that the hoist and sub-frame are positioned squarely on the truck frame before performing any welding. Mark the location for the rear hinge. This location should be immediately behind a truck cross member, approximately 32" behind the center of the rear axle on single axle trucks. Refer to Figure 1 and the charts for the specific hoist model you are installing.

WARNING: Failure to position the hoist at the proper sub-frame mounting point could cause the hoist to function improperly, leading to possible hoist, body or equipment damage.

WARNING: Failure to position the hoist at the proper sub-frame mounting point could cause the hoist to function improperly, leading to possible hoist, body or equipment damage.

FIGURE 2

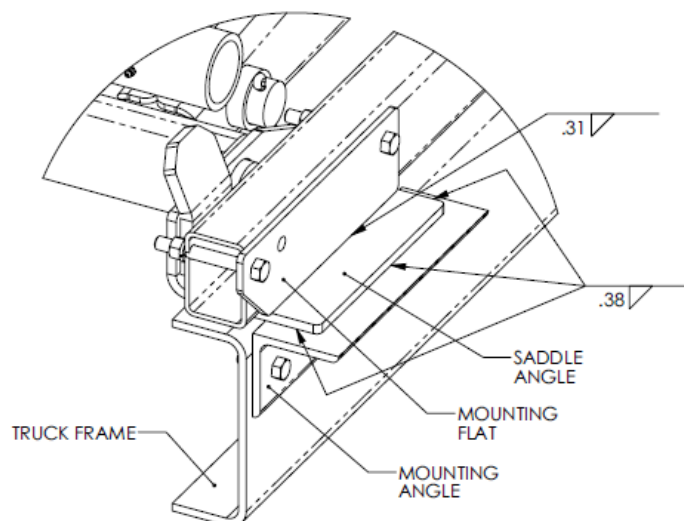

WARNING: During the first degrees of the dump cycle, the hoist lower link will move forward. Therefore, it is important to keep the areas illustrated in Figure 3 open to allow this hoist movement. Failure to do this will cause the hoist to not operate as intended and may damage the hoist and/or other truck components.

FIGURE 3

HOIST POSITION BEFORE BEGINNING OF LIFT CYCLE

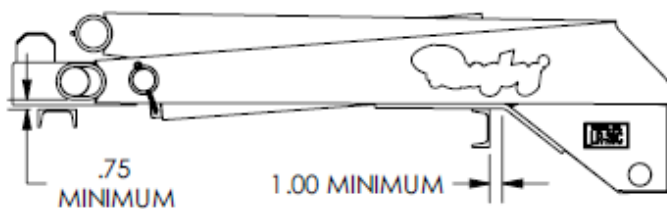

MAINTAIN SHOWN DIMENSIONS TO ALLOW ROOM FOR THE HOIST TO ROTATE FREELY DURING LIFT CYCLE.

NOTICE HOW THE HOIST MUST BE INSTALLED SUCH THAT THE OVAL SADDLE TUBE IS SLID AS FAR REARWARD AS POSSIBLE WHEN THE HOIST IS DOWN.

HOIST POSITION IN FIRST FEW DEGREES OF LIFT CYCLE



NOTICE OVAL SADDLE TUBE HAS SLID FORWARD. HOIST WILL SLIDE AHEAD ABOUT 1".

← FORWARD MOVEMENT

MAINTAIN CLEARANCE IN THIS AREA TO AVOID INTERFERENCE BETWEEN HOIST AND CROSS-MEMBER.

HOIST POSITION IN MIDDLE OF LIFT CYCLE

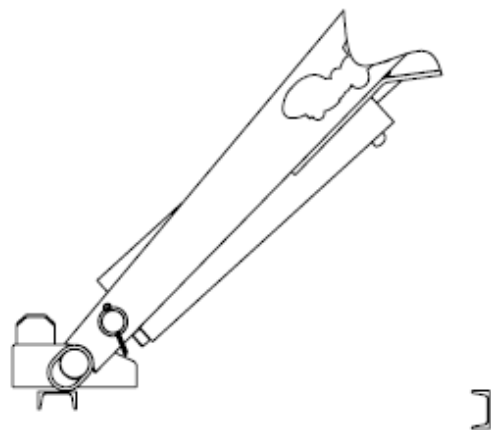

THE SIZE AND SHAPE OF CROSSMEMBERS SHOWN ARE FOR ILLUSTRATION PURPOSES ONLY.

SADDLE BRACKETS HAVE BEEN REMOVED IN THE FIGURES FOR ILLUSTRATION PURPOSES.

2. Attach the sub-frame flat brackets to the sub-frame using 1/2 x 4" bolts, lock washers, and nuts. Refer to Figure 2.
3. Attach the sub-frame guide plates to the sub-frame using 1/2 x 4" bolts, lock washers, and nuts. The guide plate should be installed in the next available hole forward of the flat bracket for the LR-26C, LR-623, or LR-2355. It should be installed in the next available hole rearward of the flat bracket for LR-28A. Refer to Figure 1.
4. With the hoist in position, attach the sub-frame to the hoist by welding each of the two sub-frame flat brackets to each of the two hoist saddle brackets. Refer to Figure 2.
5. Position a hoist mounting angle, with three holes, under the saddle bracket located on each side of the hoist. Secure each large mounting angle to the truck frame by drilling three 17/32" dia. holes and bolting the mounting angle to the truck frame. Use 1/2 x 1-1/2" bolts, lock washers, and nuts. Finally, weld each mounting angle to its respective saddle bracket. Refer to Figure 2.
6. Cut off the excess truck frame behind the sub-frame rear hinge. Weld the sub-frame rear hinge to the truck frame on both sides.

NOTE: The sub-frame model hoists are designed to set on the truck frame, as shown in Figure 1. If a cross member or some other obstacle in the truck frame interferes with the rear end of the hoist, the rear end of the hoist can be raised to clear the obstacle. The raising of the hoist rear end will not affect the lifting capacity, but raising the rear end of the hoist will raise the mounting height, ie. larger truck body long sills will be required or some cross sill notching will have to be done.

7. Install each of two lifting shaft as illustrated in Figure 4.

FIGURE 4

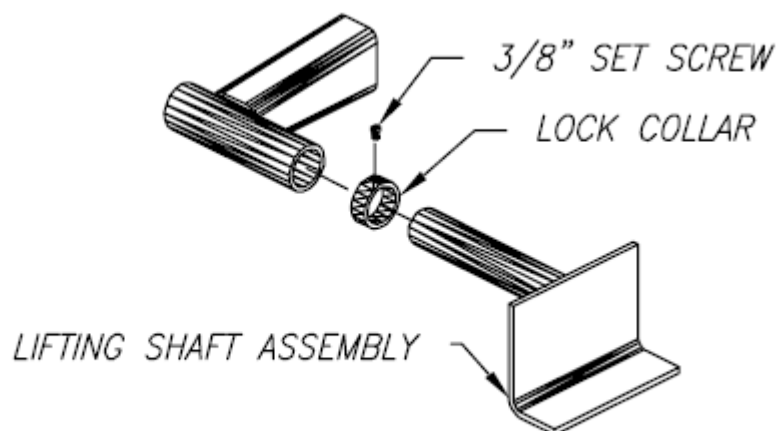

8. Position truck body on sub-frame.

NOTE: A clearance of at least 2" is required between the truck cab and the closest point on the truck body.

9. Attach each rear hinge bracket to a long beam by welding all edges where the rear hinge bracket contacts the long beam.

WARNING: The saddle tube is oblong, allowing the hoist to slide front to back. This is part of the anti-kickup design. Before performing the next step, the hoist must be pushed back as far as possible as shown in Figure 3. Failure to do so will cause the "anti-kickup device" to function improperly, causing damage to the hoist, truck body, and/or other truck components.

10. Position a lifting shaft assembly next to each channel long beam. Two 3/8" x 2.5" x 12" flats are supplied with each hoist. Weld a lift shaft to each channel long beam. Refer to Figure 5. With the lift shafts secured, slide the lock collars against the lifting tube and lock them by tightening the set screws. Refer to Figure 4.

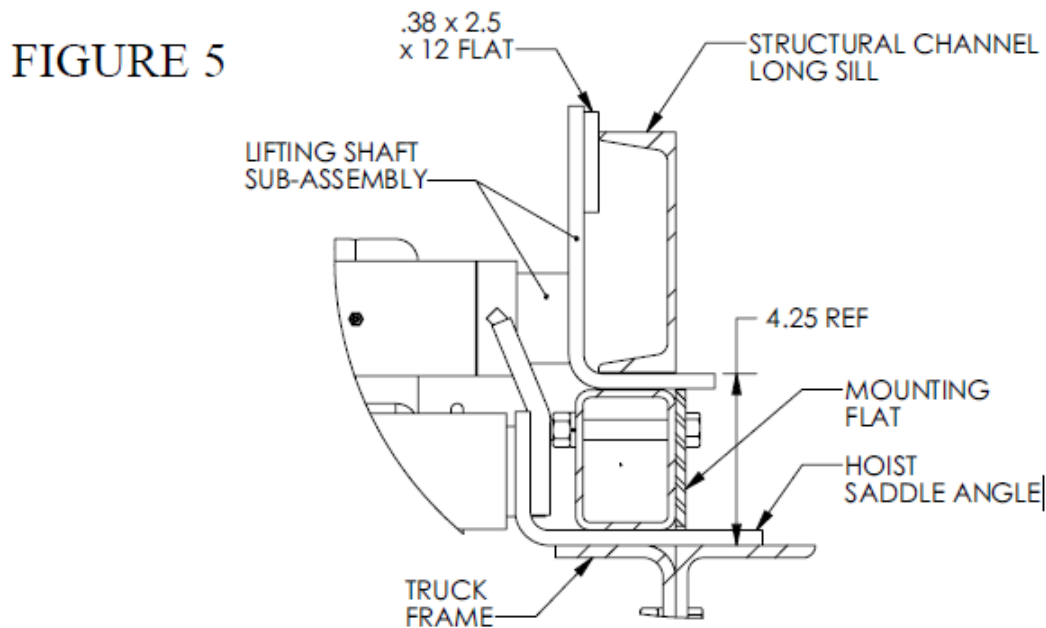

11. Install all grease fittings. For grease fitting locations in the hoist, refer to Figure 10. Torque each grease fitting to 70 in-lb. Grease all grease fittings on both the hoist and the rear hinge.
12. Install the body prop. Refer to the "**BODY PROP**" section of this manual.
13. Install the hydraulic system. Cycle the hoist several times to rid the hydraulic circuit of air.

IMPORTANT: Several different types of hydraulic components are used to power this hoist. All hydraulic systems supplied by TBEI-Rugby have an installation and operation manual included with them. For installation and operation information, refer to the Installation and Operation Manual for your particular hydraulic components. **BE SURE** to read and understand this manual and the installation and operating instructions included with the hydraulic system before you attempt to operate this hoist.

WARNING: Installing or operating this hoist without first understanding the proper installation and operation procedures can lead to serious injury or death. Always read and understand fully all installation and operation manuals before installing or operating this equipment.

NOTE: Before operating the hoist, read the "**OPERATION**" section of this manual

WARNING: If it is necessary to work on the hoist or body while in the raised position, **ALWAYS** block the unloaded body up securely with the body prop or body props.

14. Place a complete operation manual in the glove compartment of the truck. This manual **MUST BE** available for reference by the operator when needed.

WARNING: If the hydraulic system used to power this hoist was supplied by TBEI-Rugby, an operation manual will be included with the hydraulic components. The operation manual for this hydraulic system **MUST BE** supplied to the operator.

WARNING: If the hydraulic system used to power this hoist was supplied by someone other than TBEI-Rugby, an operation manual for this hydraulic system **MUST BE** obtained and supplied to the operator.

15. Install all decals. Refer to "**DECAL LOCATION**" section of this manual.

"BODY PROP"

NOTE: In order to comply with paragraph 10 of Federal Regulation #1926.601, all TBEI-Rugby hoists will be sold with one body prop. It is the responsibility of the installer to determine whether one body prop is sufficient. The following information will help in making that determination.

The body prop is designed for use only when the body is empty. The purpose of the body prop is to hold an empty body in the raised position when performing maintenance or inspection on the hoist, body, or any component that requires working under an **empty** body.

Some applications may require 2 or more body props to support the **empty** body. To determine how many body props your application requires, refer to the following information.

WARNING: Being under a raised body can result in serious injury or death should the body inadvertently descend. **Never** position yourself or allow others to position themselves under a **loaded** body. **Always** prop the **unloaded** body up using the body prop/s supplied. **Remember**, body props are to be used only on an **unloaded** body. When two props are provided, both props must be used.

WARNING: Do not use body prop to support a loaded body!

WARNING: Do not perform maintenance under a raised body without first blocking the empty body up with the body prop/s.

WARNING: Do not use a body prop that is bent or otherwise damaged. A damaged body prop will have a reduced holding capacity, and may break when used to hold up the body. This could cause serious injury or death. Replace a damaged body prop before using it.

WARNING: Be sure to install the body prop according to the "INSTALLATION OF BODY PROP" section of this manual.

The following is a step by step procedure to determine how many body props are required for this application.

1. The TBEI-Rugby Part Number 03 0703 body prop is to be used with this hoist. Determine if this is the body prop you have by referring to Figure 6.
2. Determine the "P" value referring to Figure 7. The "P" value is the horizontal distance between the rear hinge and the prop.

- Determine the "X" value referring to Figure 7. The "X" value is the horizontal distance between the body center of gravity and the rear hinge when the body is empty and down. Be sure to include any items attached to the body such as toolboxes or other structures when determining the center of gravity.

FIGURE 6

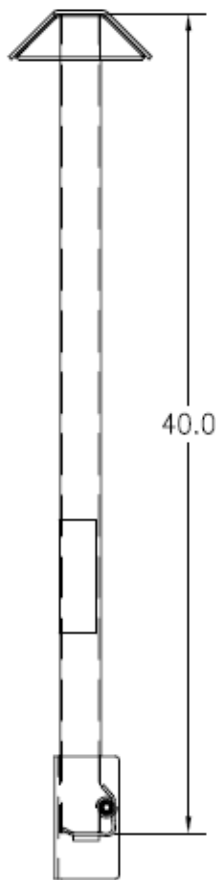

03 0703 Body Prop.
40" Tube.

FIGURE 7

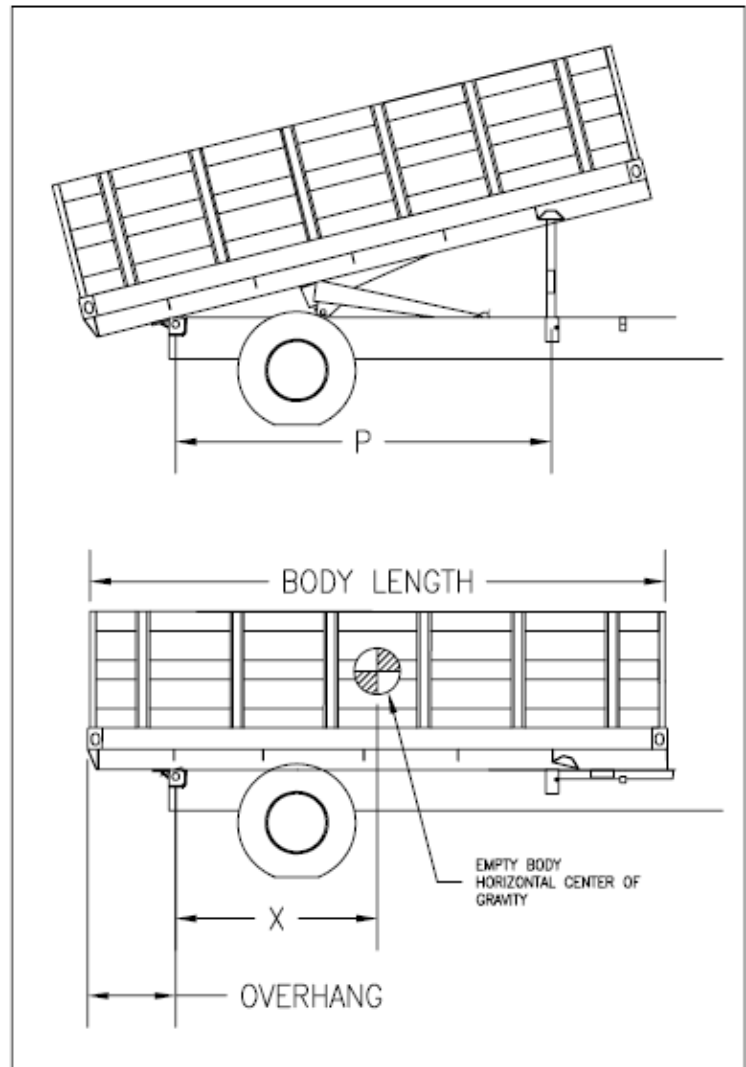

- On the left side of Chart 1, pick the "P" value for your application. On the top of the same chart, pick the "X" value for your application. Below the "X" value and to the right of the "P" value is listed an amount of weight. This represents the maximum weight that the body can weigh and be supported by only one body prop. If the body weighs more than the amount listed, 2 body props will be required. Contact TBEI-Rugby to order another body prop.

NOTE: If the body weighs more than 2 times the amount listed, another type of body prop with more weight capacity will be required, as 2 body props will not support this empty body.

CHART 1

03 0703 BODY PROP CAPACITY

Maximum Body Weight per Body Prop											
		Distance Rear Hinge - Center of Gravity (X)									
		0-36	37-48	49-60	61-72	73-84	85-96	97-108	109-120	121-132	133-144
Distance Rear Hinge - Body Prop (P)	42-47	6,100	4,500	3,500	2,800	2,300	2,000	1,700	1,500	1,300	1,100
	48-53	6,600	4,800	3,800	3,000	2,500	2,100	1,800	1,600	1,400	1,200
	54-59	7,200	5,200	4,100	3,300	2,800	2,300	2,000	1,800	1,600	1,400
	60-65	7,700	5,700	4,400	3,600	3,000	2,600	2,200	1,900	1,700	1,500
	66-71	8,300	6,100	4,800	3,900	3,300	2,800	2,400	2,100	1,900	1,700
	72-77	8,900	6,600	5,100	4,200	3,500	3,000	2,600	2,300	2,000	1,800
	78-83	9,500	7,000	5,500	4,500	3,800	3,200	2,800	2,500	2,200	2,000
	84-89	10,200	7,500	5,900	4,800	4,000	3,500	3,000	2,700	2,400	2,100
	90-95	10,800	7,900	6,200	5,100	4,300	3,700	3,200	2,800	2,500	2,300
	96-101	11,400	8,400	6,600	5,400	4,600	3,900	3,400	3,000	2,700	2,400
	102-107	12,100	8,900	7,000	5,800	4,900	4,200	3,700	3,200	2,900	2,600
	108-115	12,700	9,400	7,400	6,100	5,100	4,400	3,900	3,400	3,100	2,800
	114-119	13,400	9,900	7,800	6,400	5,400	4,700	4,100	3,600	3,200	2,900
	120-125	14,000	10,400	8,200	6,700	5,700	4,900	4,300	3,800	3,400	3,100
	126-131	14,700	10,900	8,600	7,100	6,000	5,200	4,500	4,000	3,600	3,300
	132-137	15,300	11,400	9,000	7,400	6,300	5,400	4,700	4,200	3,800	3,400
138-143	16,000	11,800	9,400	7,700	6,500	5,600	5,000	4,400	4,000	3,600	
144+	16,600	12,300	9,800	8,000	6,800	5,900	5,200	4,600	4,100	3,700	

EXAMPLE: Using a 12' body that has an empty weight of 6,000 pounds. Body is installed with a 18" overhang. The prop is located 84" forward of the rear hinge. Assume the center of gravity is 72" from the rear of the body. Subtract the overhang to get X=54". Using P=84-89, X=49-60, the maximum body weight is 5,900 pounds. This application needs 2 body props. **Remember,** this is an example only, and in no way means that this hoist **is** or **is not** acceptable to use in this application.

"INSTALLATION OF BODY PROP"

NOTE: The following steps are to be used as a guideline when installing the body prop. Since trucks will vary according to their design it is not possible to be specific about every aspect of the body prop installation.

1. Once the TBEI-Rugby hoist has been installed, raise the hoist up and temporarily block the body up. Position the prop assembly against the truck frame as illustrated in Figure 7.
2. Fasten the body prop assembly base to the truck frame.
3. Position and fasten the prop hanger to the truck frame. Hanger must be installed so that when the body is down the body prop leg will not bounce out of the hanger.
4. Position and weld the prop cup on the body as illustrated in Figure 8.

NOTE: To raise and lower body prop, see the "**OPERATION OF BODY PROP**" section of this manual.

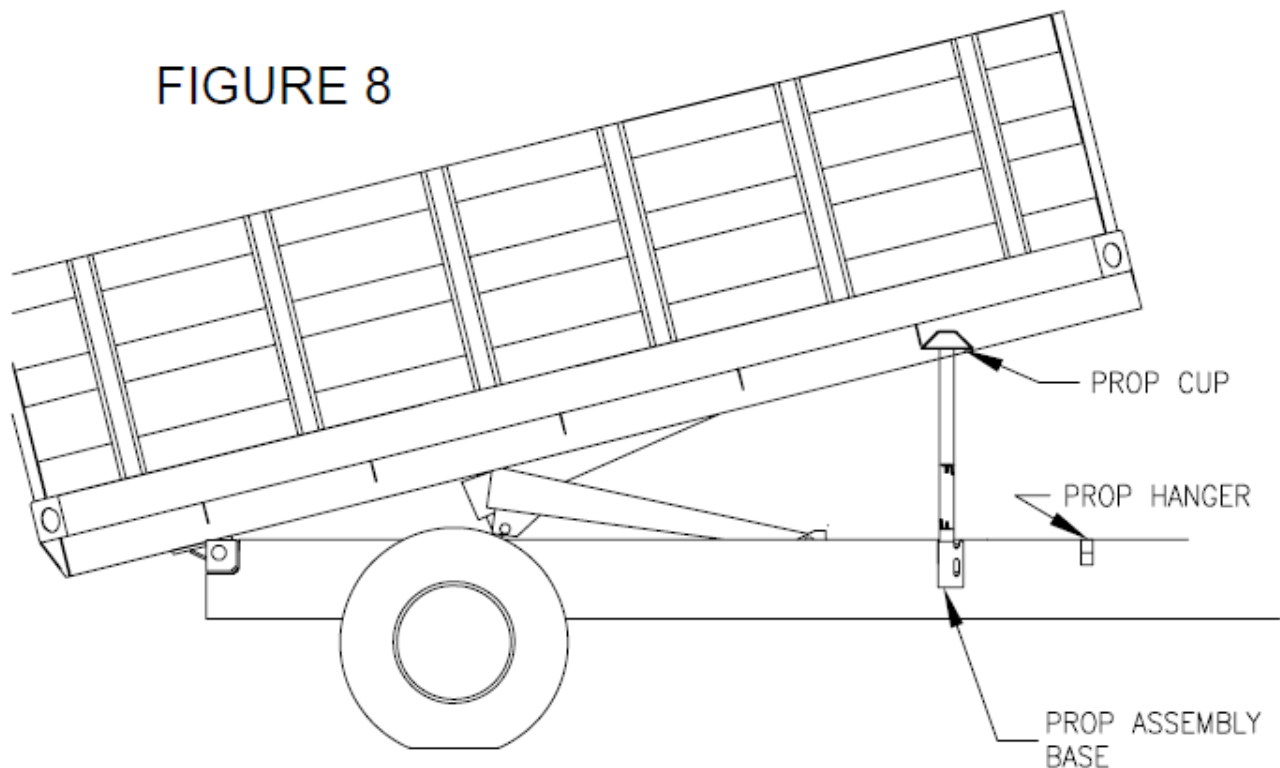

MOUNTING OF BODY PROP (FOR REFERENCE PURPOSES ONLY)

Two “DANGER” decals, as shown on this page are supplied with each hoist. These decals should be positioned as shown in Figure 9. The part number of the “DANGER” decal is 03 6039.

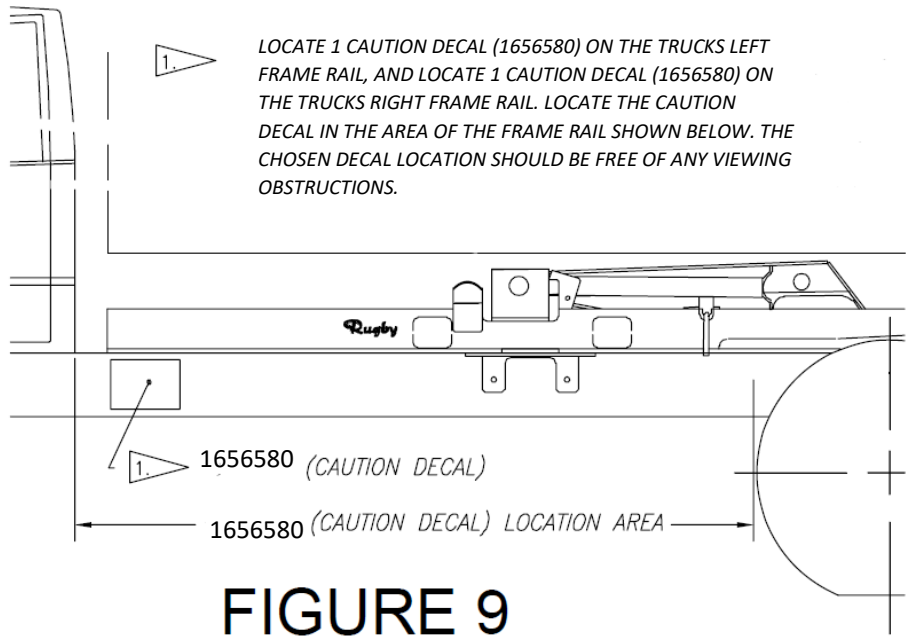

FIGURE 9

WARNING: Missing or damaged decals can cause incorrect or unsafe operation of the hoist, which can cause accidents, which may cause serious injury or death. If any decals are missing or damaged, they must be replaced.

To obtain replacement decals, contact your TBEI-Rugby dealer or call 1-701-776-5722 or 1-800-869-9162.



DANGER



1. STAY OUT FROM UNDER BODY WHEN HOIST IS OPERATING.
2. DURING DUMPING OPERATIONS, NO ONE MUST BE ALLOWED TO STAND IN OR MOVE THROUGH THE AREA WHERE THE BODY AND HOIST OPERATE OR INTO AN AREA WHERE AN UPSET LOAD MIGHT FALL.
3. OPERATOR MUST REMAIN AT CONTROLS IN CAB DURING DUMPING OPERATIONS.
4. **NEVER** LEAVE BODY RAISED OR PARTLY RAISED WHILE VEHICLE IS UNATTENDED OR PERFORMING MAINTENANCE OR SERVICE UNDER BODY, UNLESS BODY IS BRACED TO PREVENT ACCIDENTAL LOWERING.
5. IF HOIST PUMP IS PTO DRIVEN, ALWAYS DISENGAGE PTO WHEN HOIST IS NOT IN USE OR WHEN MOVING VEHICLE.
6. DO NOT ATTEMPT TO RAISE A LOADED BODY WHEN THE VEHICLE IS ON UNLEVEL GROUND.



Rugby[®]
MANUFACTURING CO.

"LUBRICATION"

IMPORTANT: All grease fittings should be greased at least twice annually. Refer to Figure 12 for grease fitting locations. Failure to grease hoist will result in hoist failure. Hoist failure due to lack of grease is not covered by the warranty.

IMPORTANT: Refer to installation and operation manual of the hydraulic system for hydraulic system lubrication instructions.

1. Grease all of the grease fittings in the hoist frame itself. Apply grease until excess grease can be seen coming out the ends of the tubes. Refer to Figure 10 for grease fitting locations. Replace any missing or broken grease fittings.
2. Grease the two grease fittings in the truck rear hinge.
3. Check oil level in the pump reservoir every time the oil is changed in the truck engine. **REMEMBER** keep the oil clean. An annual oil change can prevent contaminants from ruining your pump and hoist cylinder.

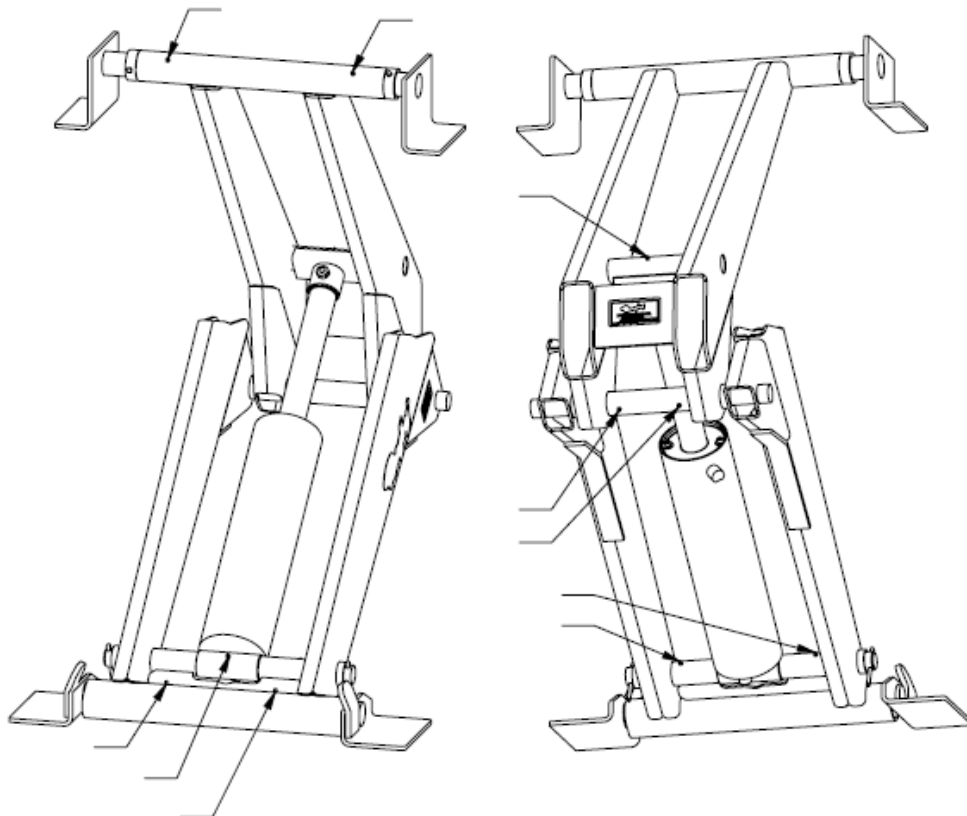

**FIGURE 10A: LR-26C, LR-623, or LR-28A GREASE ZERK LOCATIONS
10 ZERKS TOTAL**

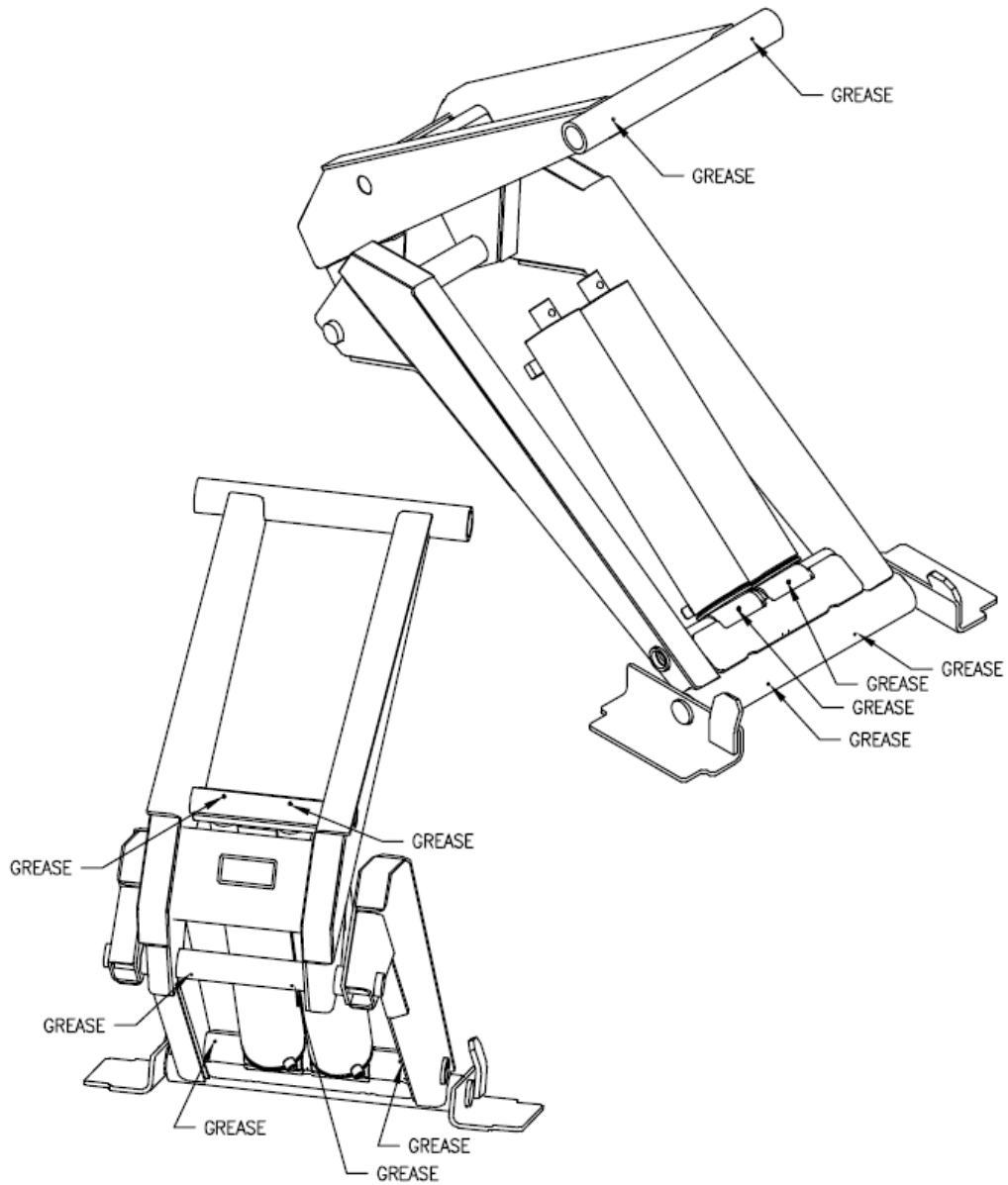

FIGURE 10B: LR-2355 GREASE ZERK LOCATIONS
12 ZERKS TOTAL

"OPERATION OF BODY PROP"

WARNING: Being under a raised body can result in serious injury or death should the body unexpectedly descend. **Never** position yourself or allow others to position themselves under a **loaded** body. **Always** prop the **unloaded** body up using the body prop or body props supplied. **Remember**, body props are to be used only on an **unloaded** body. When two props are provided, both props must be used.

Below is a step-by-step procedure for using the body prop.

1. Raise body to sufficient height and shut off all power.
2. Grasp prop handle at arms length and rotate prop upwards.
3. Swing prop up to vertical position and push down until prop locks in line with support bracket on body.
4. Using inside-the-cab controls, lower body slowly until prop contacts prop cup.

CAUTION: Do not power hoist down while on prop.

5. To lower prop for normal operation, "reverse" the procedure of the above four steps.

"OPERATION OF HOIST AND PUMP"

WARNING: Operating this hoist without first understanding the proper operation procedures can lead to serious injury or death. Always read and understand fully all operation manuals before using or operating this equipment.

WARNING: An operation manual for the hydraulic system should be available. The operation manual for the supplied hydraulic system **MUST BE** read and understood before operating this trailer.

WARNING: Being under a raised body can result in serious injury or death should the body unexpectedly descend. **Never** position yourself or allow others to position themselves under a **loaded** body. **Always** prop the **unloaded** body up using the body prop or body props supplied. **Remember**, body props are to be used only on an **unloaded** body.

DANGER:

1. Stay out from under body when hoist is operating.
2. During dumping operations, no one must be allowed to stand in or move through the area where the body and hoist operate or into an area where an upset load might fall.
3. Controls must be in a safe location and operator must remain at controls during the dumping operation. Controls must be permanently located in truck cab or another location where it is not possible to be under body during dumping operation.
4. **Never** leave body raised or partly raised while the truck is unattended or while performing maintenance or service under body, unless body is braced to prevent accidental lowering.
5. If hoist pump is direct engine driven by truck, always disengage drive when hoist is not in use or when moving load.
6. **Do not** attempt to raise a loaded body when the vehicle is on un-level ground.
7. Never jerk or shock a raised body to loosen a stuck load.

WARNING: Freeing a stuck load during dumping, with the body raised, by jerking or shocking the truck, may cause damage to the truck, serious injury or death. **Never** drive forward or rearward and stop quickly with the load up or otherwise shock the load. If a load is stuck in the body, lower the body, then free the load.

WARNING: Attempting to dump a load on un-level ground may cause the truck to over turn and can result in damage, serious injury or death. **Always** dump the load on ground that is level front to rear as well as level side to side.

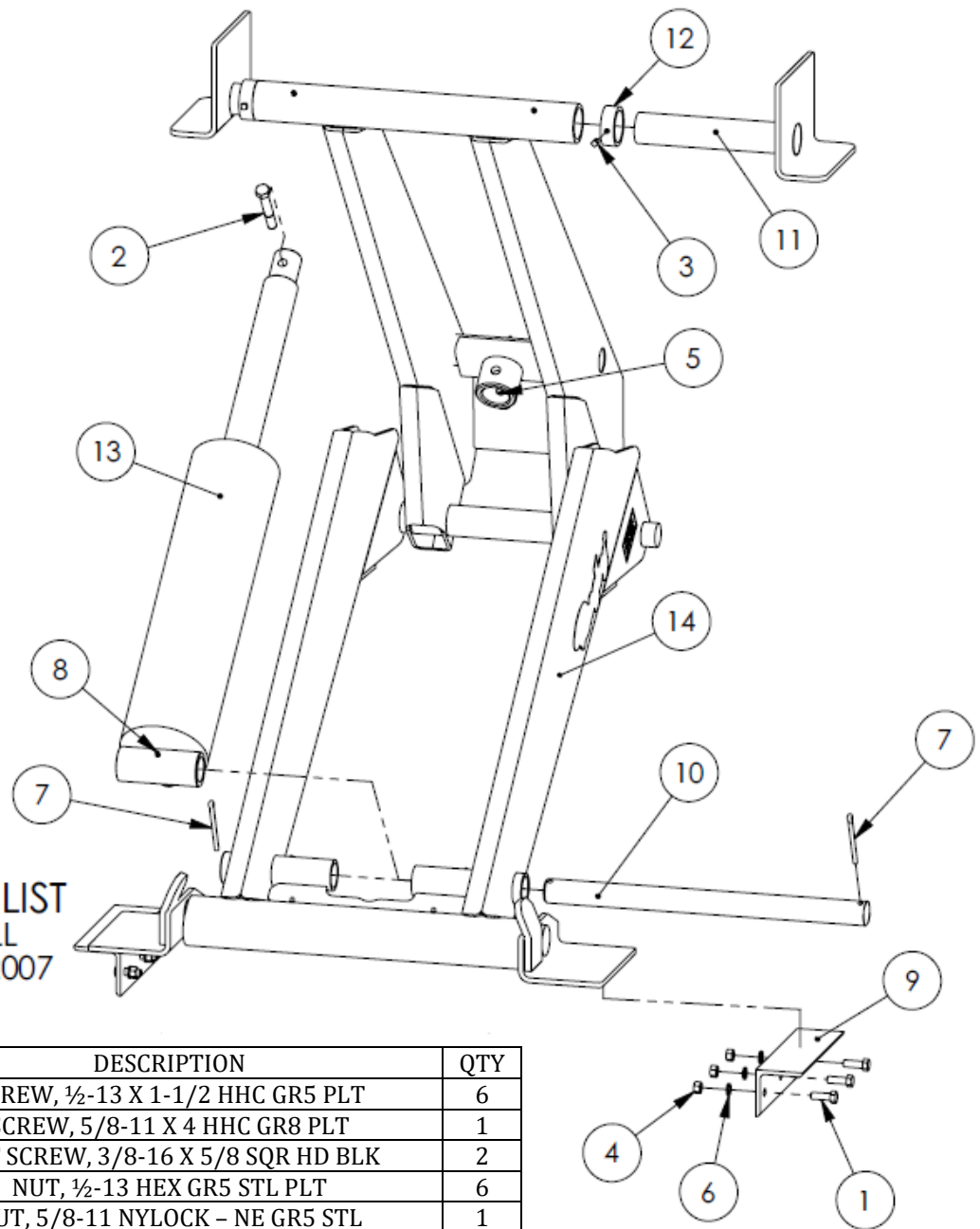

LR-26C PARTS LIST
SUB-FRAME INSTALL
 EFFECTIVE 08/15/2007

ITEM	PART #	DESCRIPTION	QTY
1	1653827	SCREW, 1/2-13 X 1-1/2 HHC GR5 PLT	6
2	1653838	SCREW, 5/8-11 X 4 HHC GR8 PLT	1
3	1653845	SET SCREW, 3/8-16 X 5/8 SQR HD BLK	2
4	1653860	NUT, 1/2-13 HEX GR5 STL PLT	6
5	1643070	NUT, 5/8-11 NYLOCK - NE GR5 STL	1
6	1653880	WASHER, 1/2 LOCK PLATED	6
7	1653921	PIN, 5/16" X 3-1/2" ZP COTTER	2
8	1520370	FITTING, 1/4-28" THREAD FORMING GREASE	10
9	1654936	ANGLE, 11.5 MOUNTING	2
10	1654950	SHAFT, LR-28/26 CYLINDER PIN	1
11	1655512	WELDMENT, SF 2.25 DIA LIFTING	2
12	1656191	COLLAR, 2.25 LOCK	2
13	1621268	CYLINDER, 6 X 20, 2.5 ROD, 2.0 NECK	1
14	1657062	FRAME, LR-26C PCBLK HOIST	1

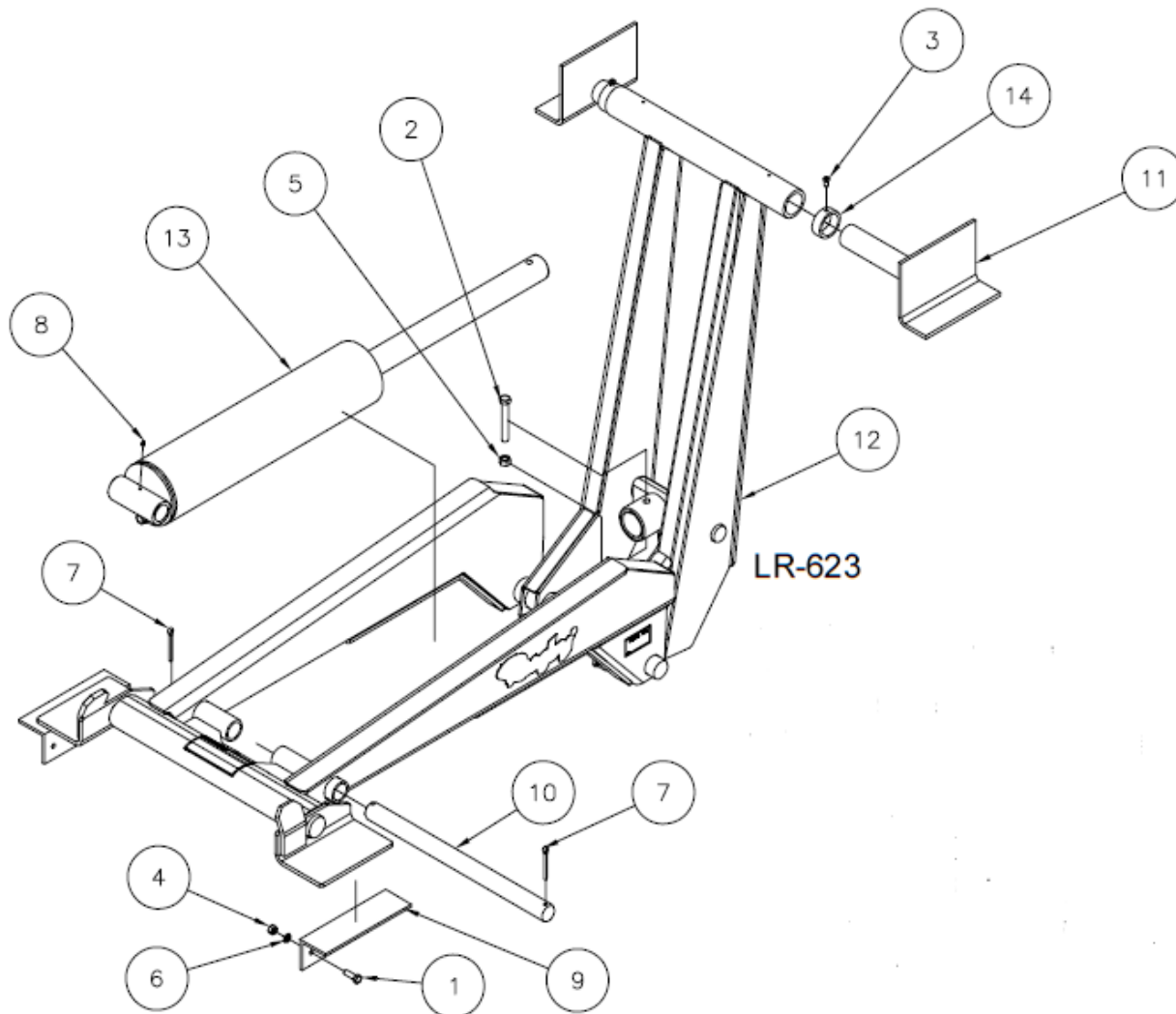

ITEM	PART #	DESCRIPTION	QTY
1	1653827	SCREW, 1/2-13 X 1 1/2 HHC GR5 PLT	6
2	1653838	SCREW, 5/8-11 X 4 HHC GR8 PLT	1
3	1653845	SET SCREW, 3/8-16 X 5/8 SQR HD BLK	2
4	1653860	NUT, 1/2-13 HEX GR5STL PLT	6
5	1643070	NUT, 5/8-11 NYLOCK-NE GR5 STL	1
6	1653880	WASHER, 1/2 LOCK PLATED	6
7	1653921	PIN, 5/16" X 3-1/2" ZP COTTER	2
8	1520370	FITTING, 1/4-28" THREAD FORMING GREASE	10
9	1654936	ANGLE, 11.5 MOUNTING	2
10	1654950	SHAFT, LR-28/26 CYLINDER PIN	1
11	1655512	WELDMENT, SF 2.25 DIA LIFTING	2
12	1655951	FRAME, LR-623 PCBLK HOIST	1
13	1621264	CYLINDER, 6 X 23	1
14	1656191	COLLAR, 2.25 LOCK	2

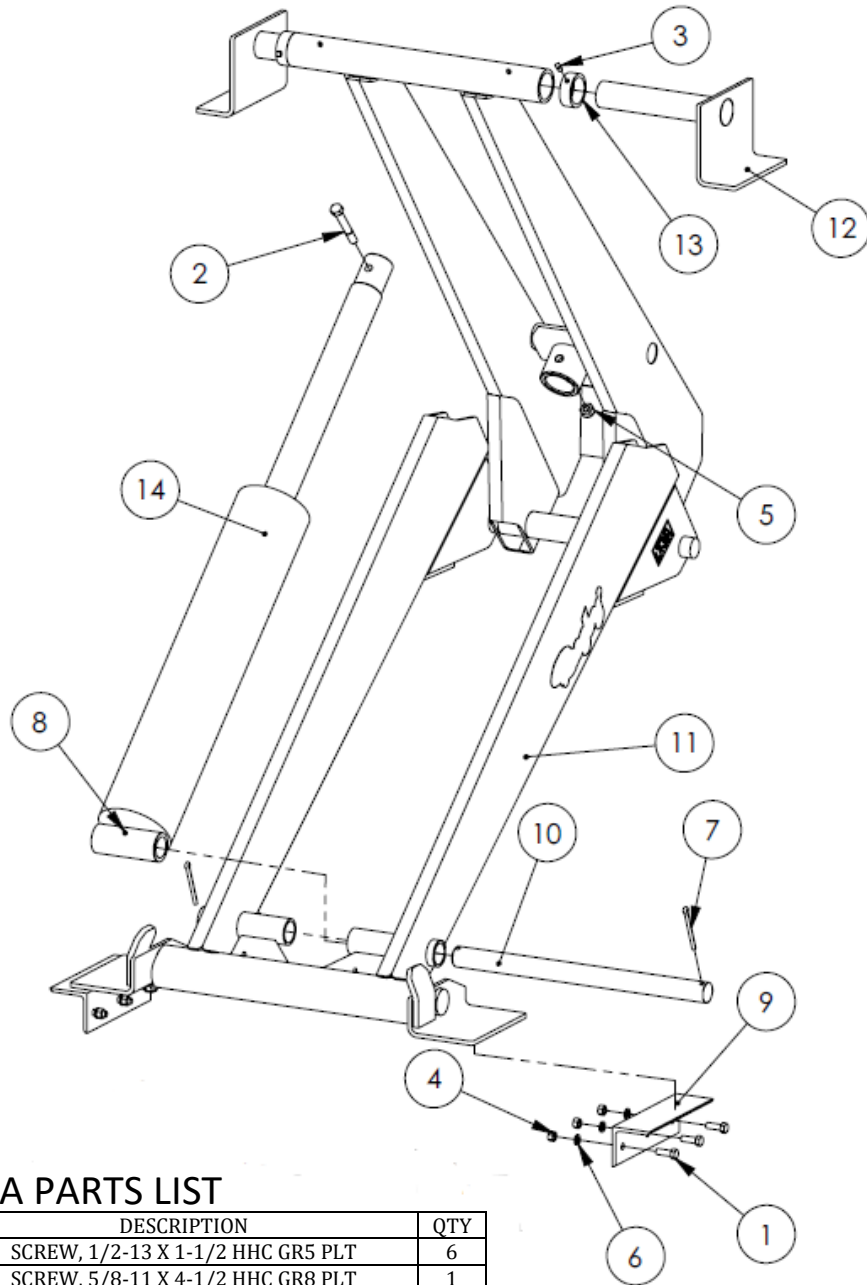

LR-28A PARTS LIST

ITEM	PART #	DESCRIPTION	QTY
1	1653827	SCREW, 1/2-13 X 1-1/2 HHC GR5 PLT	6
2	1653840	SCREW, 5/8-11 X 4-1/2 HHC GR8 PLT	1
3	1653845	SET SCREW, 3/8-16 X 5/8 SQR HD BLK	2
4	1653860	NUT, 1/2-13 HEX GR5 STL PLT	6
5	1643070	NUT, 5/8-11 NULOCK - NE GR5 STL	1
6	1653880	WASHER, 1/2 LOCK PLATED	6
7	1653921	PIN, 5/16" X 3-1/2" ZP COTTER	2
8	1520370	FITTING, 1/4-28" THREAD FORMING GREASE	10
9	1654936	ANGLE, 11.5 MOUNTING	2
10	1654950	SHAFT, LR-28/26 CYLINDER PIN	1
11	1655288	FRAME, LR-28A PCBLK HOIST	1
12	1655512	WELDMENT, 2.25DIA LIFTING	2
13	1656191	COLLAR, 2.25 LOCK	2
14	1621270	CYLINDER, 6X28, 2.75 ROD, 2.5 NECK	1

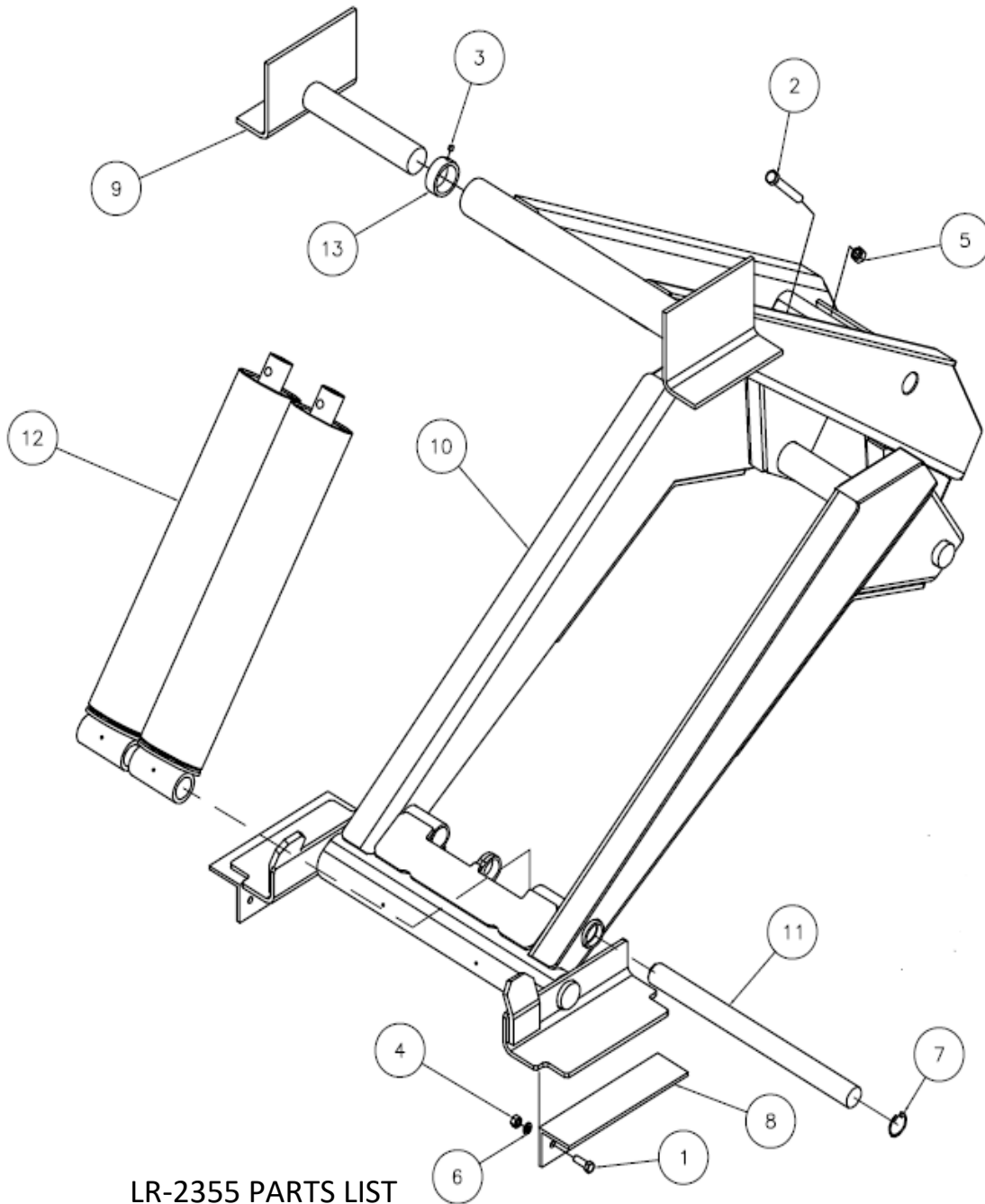

LR-2355 PARTS LIST

ITEM	PART #	DESCRIPTION	QTY
1	1653827	SCREW, 1/2-13 X 1-1/2 HHC GR5 PLT	6
2	1653838	SCREW, 5/8-11 X 4 HHC GR8 PLT	2
3	1653845	SET SCREW, 3/8-16 X 5/8 SQR HD BLK	2
4	1653860	NUT, 1/2-13 HEX GR5 STL PLT	6
5	1643070	NUT, 5/8-11 NYLOCK - NE GR5 STL	2
6	1653880	WASHER, 1/2 LOCK PLATED	6
7	1653939	RING, INTERNAL - 181 SNAP	2
8	1654979	ANGLE, 13.5 MOUNTING	2
9	1655512	WELDMENT, 2.25DIA LIFTING	2
10	1655836	FRAME, LR-2355 PCBLK HOIST	1
11	1655840	SHAFT, LR2355 CYLINDER PIN'G	1
12	1621262	5 X 23 CYL ASSY/BLACK/ORING	2
13	1656191	COLLAR, 2.25 LOCK	2