

FRONT VIEW

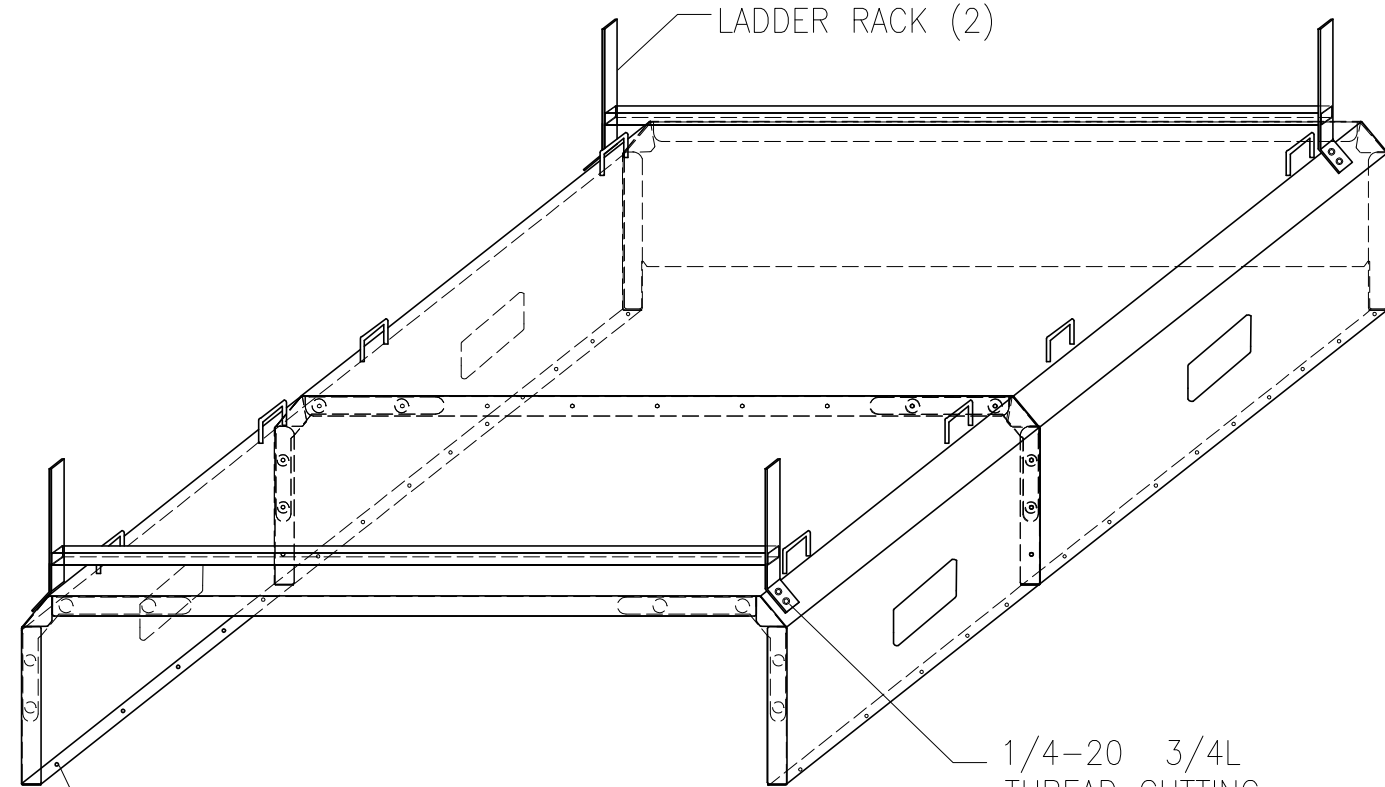

LADDER RACK (2)

1/4-20 3/4L
THREAD CUTTING
SCREW (8)

BOLT SERRATED FLANGE
3/8 DIA. x 1"L (15)

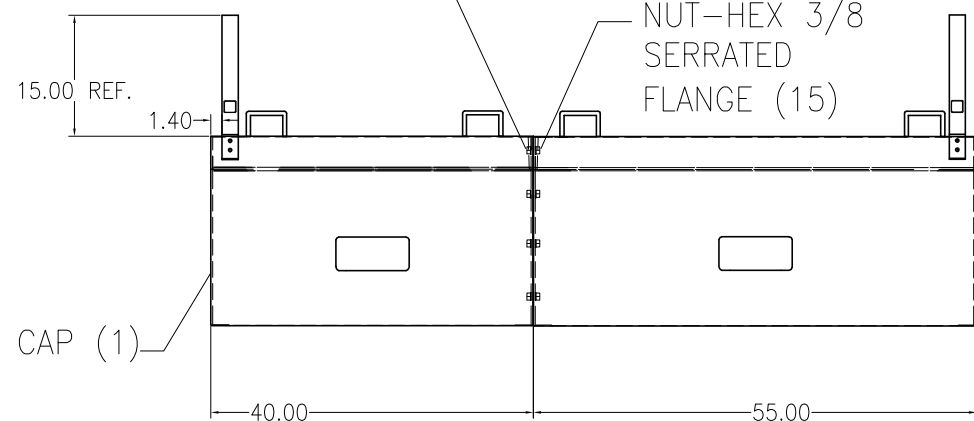

NUT-HEX 3/8
SERRATED
FLANGE (15)

15.00 REF.

1.40

REAR CAP (1)

40.00

55.00

FRONT CAP
W/PANEL (1)

SIDE VIEW

1/4-20 3/4L
THREAD CUTTING
SCREW (29)

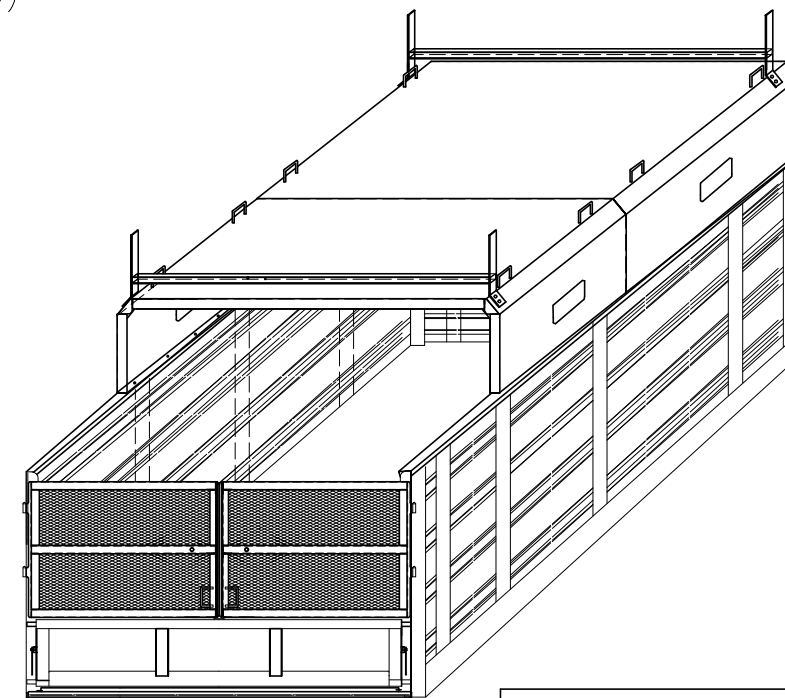

LANDSCAPER CAP INSTALLATION

- ① FIRST, POSITION THE CAP WITH THE FRONT PANEL IN FRONT OF THE LANDSCAPER, AND ON TOP OF THE TARP RAIL, SYMMETRICALLY, ON BOTH SIDES.
- ② SECOND, POSITION THE OTHER CAP RIGHT NEXT TO THE FIRST ONE. MAKE SHURE THE TWO CAPS ARE LINED UP AND SYMMETRICAL TO THE BODY.
- ③ THAN, BOLT THE TWO PIECES TOGETHER WITH THE ENCLOSED IN THE KIT SERRATED BOLTS AND NUTS.
- ④ USE THE THREAD CUTTING SCREWS AVAILABLE IN THE KIT TO ATTACH THE TWO PIECES TO THE TARP RAIL.
- ⑤ POSITION AND ATTACH THE LADDER RACK TO THE CAP, AS IT IS SHOWN ON THE PRINT.

CONFIDENTIAL No copying or use without the express consent of Rugby Manufacturing Co.		 MANUFACTURING CO. <small>INDUSTRIAL PARK • BOX 229 RUGBY, NORTH DAKOTA 58368</small>	
Drawn by	LIT	Date	03-22-01
Checked by		TOLERANCE UNLESS OTHERWISE SPECIFIED	LINEAR ±.03 ANGULAR ±.5°
Approved by		Drawing Number	DWG00010
SCALE	0.06=1.00	TITLE	LANDSCAPER CAP INSTALLATION