

# Rugby Manufacturing Manual

## RANCHER INSTALLATION & OPERATION MANUAL



### INTRODUCTION

*IMPORTANT!! Read this manual thoroughly prior to installation and operation. This manual outlines the installation and operation of a Rancher platform manufactured by Rugby Manufacturing Co. This manual should be kept readily accessible for any potential operator at all times. Should you have any questions or concerns, please contact your dealer or a Rugby Manufacturing customer service representative before*

Toll Free: 1-800-869-9162 • Office: 1-701-776-5722 • Fax: 1-701-776-6235  
Visit [www.rugbymfg.com](http://www.rugbymfg.com) for further information.

**Body Serial Number:** \_\_\_\_\_

**In Service Date:** \_\_\_\_\_

# Rugby Manufacturing Rancher Manual

## Table of Contents

<b>How to Use This Manual</b> .....	1
Lables.....	1
<b>Reference Information</b> .....	1
Serial Number .....	1
Torque Values Chart.....	2
<b>General Safety</b> .....	2
<b>General Warnings</b> .....	3
<b>Assembly &amp; Installation</b> .....	4-8
Bulkhead Installation.....	4
General Installation .....	5-6
Lighting Configuration.....	7
<b>Maintenance &amp; Operation</b> .....	8



# Rugby Manufacturing Rancher Manual

## How To Use This Manual

This manual provides guidelines, and instructions for correctly assembling, operating and maintaining your Rugby Manufacturing product. Any and all people that own and operate this product must read and fully understand each section in this manual.

Labels:

Throughout this manual, the three following types of labels will be used: danger, warning, and caution. It is imperative that all labels are obeyed, for the safety of the operator.



Indicates a hazardous situation which, if not avoided, will result in death or serious injury.



Indicates a hazardous situation which, if not avoided, could result in death or serious injury.



Indicates a hazardous situation which, if not avoided, could result in minor or moderate injury.

## Reference Information

Serial Number:

This information is required for any warranty or service inquiries, and should be recorded on the front page of this manual for easy reference.

The serial number plate is located on the front of the bulkhead, facing the cab on the drivers side .

**Figure 1 Serial Plate Location**

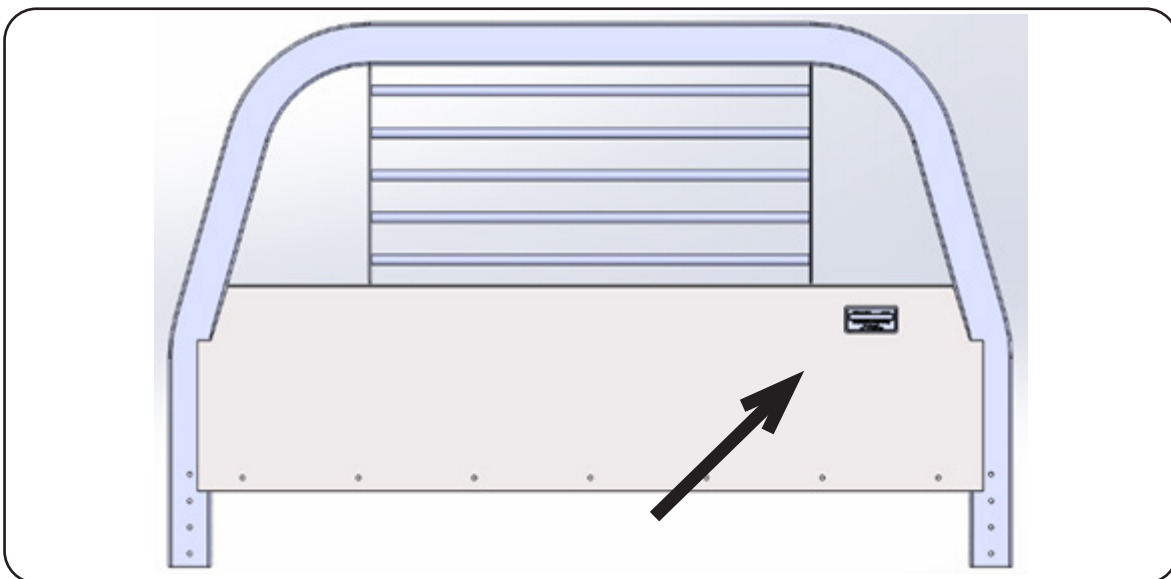



# Rugby Manufacturing Rancher Manual

## Reference Information

### Torque Values

This chart is to be used as a guide during installation.

Figure 2 Torque Values Chart

Size	Grade 2 Torque	Grade 5 Torque	Grade 8 Torque
			
1/4-20	3-4 lb-ft	6-7 lb-ft	10-11 lb-ft
1/4-28	4-5 lb-ft	8-9 lb-ft	11-12 lb-ft
5/16-18	8-9 lb-ft	14-15 lb-ft	21-22 lb-ft
5/16-24	9-10 lb-ft	15-16 lb-ft	21-22 lb-ft
3/8-16	17-18 lb-ft	24-26 lb-ft	37-40 lb-ft
3/8-24	19-20 lb-ft	28-30 lb-ft	40-43 lb-ft
1/2-13	38-42 lb-ft	60-65 lb-ft	90-100 lb-ft
1/2-20	43-47 lb-ft	70-75 lb-ft	95-15 lb-ft
5/8-11	75-80 lb-ft	122-130 lb-ft	180-190 lb-ft
5/8-18	85-90 lb-ft	145-150 lb-ft	200-210 lb-ft
3/4-10	132-140 lb-ft	220-230 lb-ft	315-330 lb-ft
3/4-16	152-160 lb-ft	250-260 lb-ft	355-370 lb-ft

## General Safety

Installation of the bulkhead and associated components requires two people to accomplish easily and safely. Avoid placing hands or other body parts in locations where they could be pinched or crushed by the components during installation.

### DANGER

Bouncing or jerking of the hoist is to be avoided as it may result in component failure, injury or death.

### DANGER

Do not raise or drive a raised body against another object. Doing so could result in equipment or property damage, injury or death.

### DANGER

Overloading of a truck can cause truck component damage, injury or death. Never exceed the gross vehicle weight (GVW) or gross axle weight (GAW) rating of your vehicle.

# Rugby Manufacturing Rancher Manual

---

## General Warnings:

- Welding, oxy-fuel cutting, or grinding sparks can cause fuel to ignite that in turn can lead to injury or death. Always take adequate steps to avoid ignition of fuel from fuel tanks when welding, grinding, or oxy-fuel cutting during equipment installation.
- Heat from the truck's exhaust system can cause hydraulic component failure and may lead to a fire that could cause injury or death. Always install equipment in locations where heat from the exhaust system will not damage any hydraulic component.
- Malfunctioning equipment can cause property damage, injury or death. Always have faulty equipment repaired before continuing its use. Consult the manufacturer if required.
- The inadvertent shorting of the vehicle's electrical supply can cause a fire or equipment-damage that could lead to injury or death. Always disconnect the vehicle battery prior to installing, servicing, or repairing electrical items.
- Damage to brake lines during equipment installation or installing bolts or equipment in such a way that the line will rub and become damaged can lead to brake failure which can cause an accident and can lead to severe injury or death. Always take adequate steps to prevent brakeline damage during installation and isolate brake lines from installed equipment.
- Check load making sure that rocks, equipment, or any other object will not fall off of vehicle while driving vehicle. Falling objects can cause equipment or property damage, bodily injury or death.
- Make sure all doors are closed and latched before moving vehicle. Swinging doors or falling objects can cause equipment or property damage, bodily injury or death.
- Overloading of a vehicle can cause vehicle component damage or an accident which may cause injury or death. Never exceed the gross vehicle weight (GVWR) or the gross axle weight (GAWR) rating or gross combined vehicle rating (GCWR) of your vehicle.
- Not installing or operating equipment correctly can cause component damage or an accident which may cause injury or death. Always install and operate equipment in accordance with manufacturers' instructions. Read and understand this manual fully before proceeding.
- Missing or damaged decals can lead to accidents that may cause serious injuries or death.

# Rugby Manufacturing Rancher Manual

## Assembly & Installation

### Bulkhead Installation

1. There are two mounting heights for the bulkhead:
  - The bulkhead ships positioned approximately 42" height from deck to top of bulkhead.
  - For taller applications, remove the bulkhead and install the filler plate, using kit. Use the top row of predrilled holes to attach the filler plate to the bulkhead and the bottom row of holes to attach the filler plate to the body.
  - The installation of the filler plate will bring the bulkhead height to approximately 45" from the deck to the top of the bulkhead.
1. Refer to [Figure 2](#) for torque guidelines.
2. Refer to [Figure 4](#) for bulkhead installation bolt alignment.

**Figure 4 Bulkhead Installation**

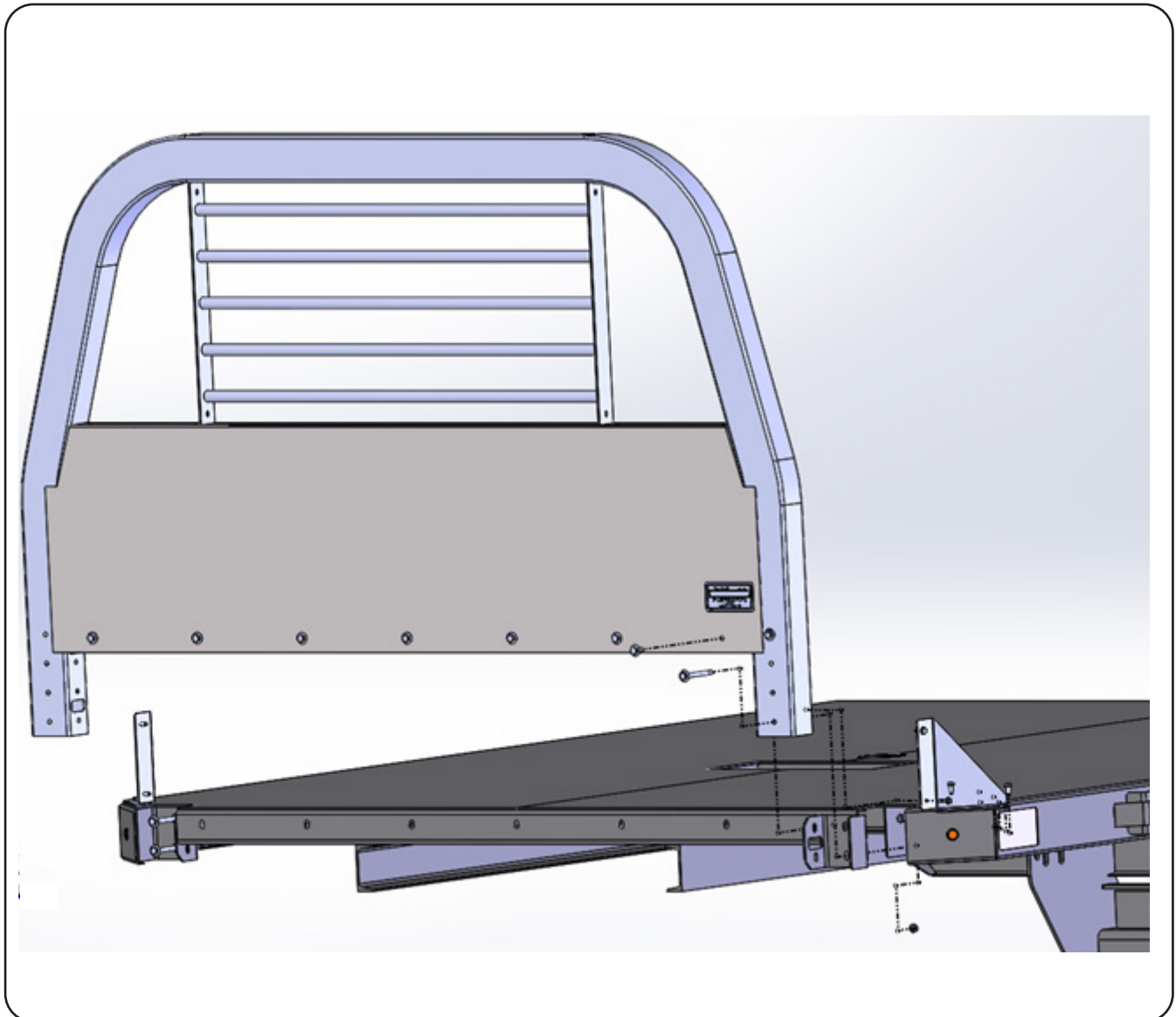

# Rugby Manufacturing Rancher Manual

## Assembly & Installation

**NOTE:** The following steps are to be followed as a general guideline when assembling and installing the Rancher body. Follow all truck manufacturers' recommendations for installing this body. The manufacturers' recommendations should be followed if there is a difference between them and this manual.

**WARNING:** Do not weld to the vehicle frame. Do not drill any new holes in the top flange of the vehicle frame. Keep all drilled holes in the middle 1/3 of the vehicle frame. Doing otherwise will weaken the vehicle frame which can result in vehicle damage, injury, or death

**NOTE:** Refer to [Figure 3](#) for installation of the Rancher body to the truck frame. The Rancher body may be installed directly on top of the chassis rails, or it may be installed with a sleeper between the chassis and the body. A sleeper may be installed to allow the body to clear rivet heads or other obstructions found on the vehicle frame. Suitable sleepers may be constructed of wood, rubber, or steel. The sleeper should have a slight taper (to minimize stress on the chassis frame) which starts at the front of the Rancher frame.

**WARNING:** Maintain at least a 3" clearance between the front of the Rancher body and the back of the truck cab, or a clearance as specified by the chassis manufacturer. This is required to meet FMVSS regulations. If an adequate clearance is not maintained, the Rancher body may shift into the truck cab during an accident, resulting in injury or death.

**Figure 3 Cab to Bulkhead Spacing (3" minimum)**

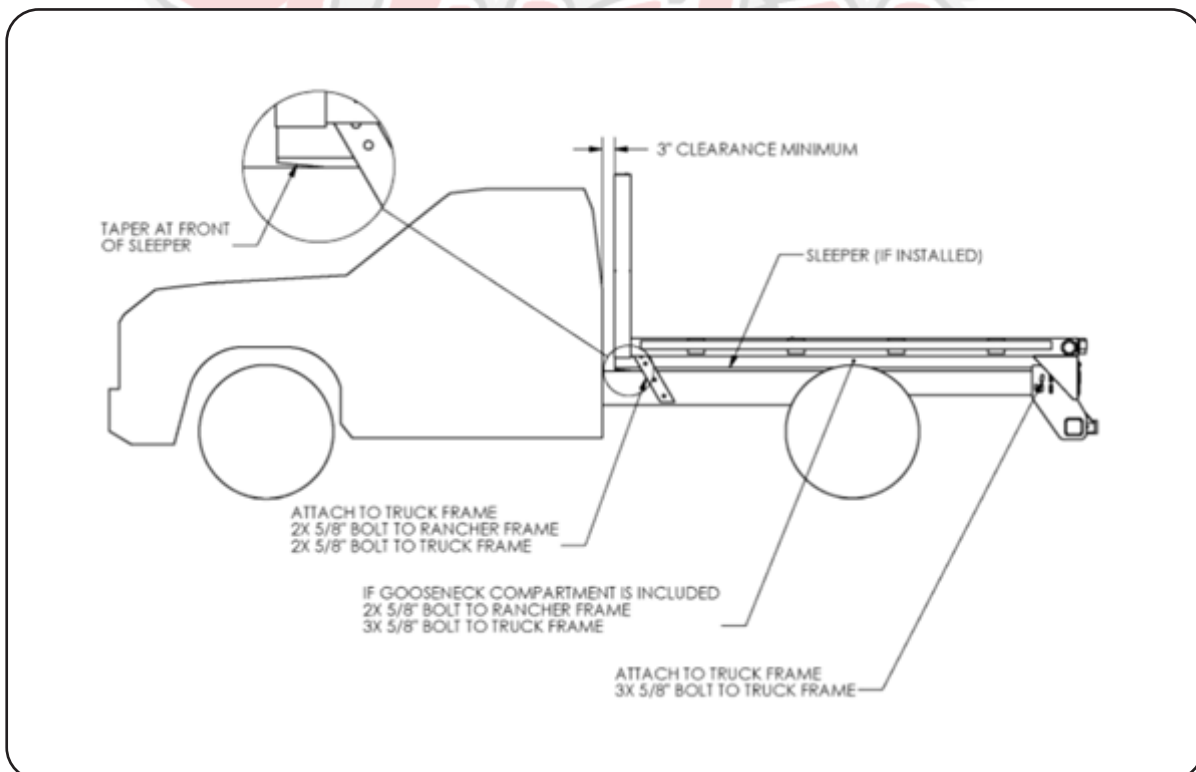



# Rugby Manufacturing Rancher Manual

---

## Assembly & Installation cont.

**NOTE:** Shear plates are not included in the installation carton.

1. Use 5/8" diameter grade 8 bolts, nuts, and washers when attaching the Rancher body to the truck frame. These bolts should be tightened to 60-65 ft-lbs of torque. A "shear plate" installation is the typical method for securing the Rancher body to the truck frame. The shear plates should be a minimum of 1/4" x 3" steel plate.
2. The front shear plate should be angled 45 to 60 degrees from the horizontal. The front shear plate should be located at least 4" from the front of the body to allow for frame flexing. The front shear plate should be attached with a minimum of 2x 5/8" bolts to the truck frame rail, and 2x 5/8" bolts to the Rancher frame.
3. The rear shear plate should be attached to the truck frame with a minimum of 3x 5/8" bolts to the truck frame, and 2x 5/8" bolts to the Rancher frame. If the body was ordered with a receiver hitch, plates have already been welded onto the Rancher body in the rear shear plate area. These eliminate the need for additional rear shear plates. They should be attached to the truck frame with a minimum of 3x 5/8" bolts.
4. If the body includes a gooseneck mount, then the body needs to be attached to the truck frame in the area of the gooseneck. The gooseneck hitch assembly needs to be attached to the chassis frame. A shear plate should be attached to the truck frame with a minimum of 3x 5/8" bolts.
5. Follow manufacturer's recommendation for installing fuel filler and/or DEF fill components. Fuel fill components must be securely attached to the body.
6. Install and securely attach chain attachments as required.

**NOTE: The gooseneck Maximum Gross Trailer Weight for the Rancher body with a gooseneck compartment is 30,000 lbs. The rated vertical coupler load (tongue weight) is 7,500 lbs. This will be reduced if any other component of the towing system has a lower rating.** If the truck, gooseneck ball, safety chains, trailer components, etc are rated lower than 30,000 lbs, the lowest rating should be used to determine the Maximum Gross Trailer Weight of the complete setup.

7. Grease hitch ball regularly, keep gooseneck area free of dirt and debris. Check for: damaged parts before each use, bent or warped metal, cracked or failed welds, excessive wear on ball. Check bolts before each use. If a bolt is loose, check for wear of the hole, or damage to the surrounding metal. Do not use if anything is damaged, Tighten any loose bolts.
8. If a receiver hitch is included with the Rancher body, the Maximum Gross Trailer Weight is 20,000 lbs with a Maximum Vertical Tongue Load of 2,000 lbs. Never exceed towing capacity of vehicle, receiver hitch, or any part of towing system.



# Rugby Manufacturing Rancher Manual

## Assembly & Installation

Figure 5 Lighting

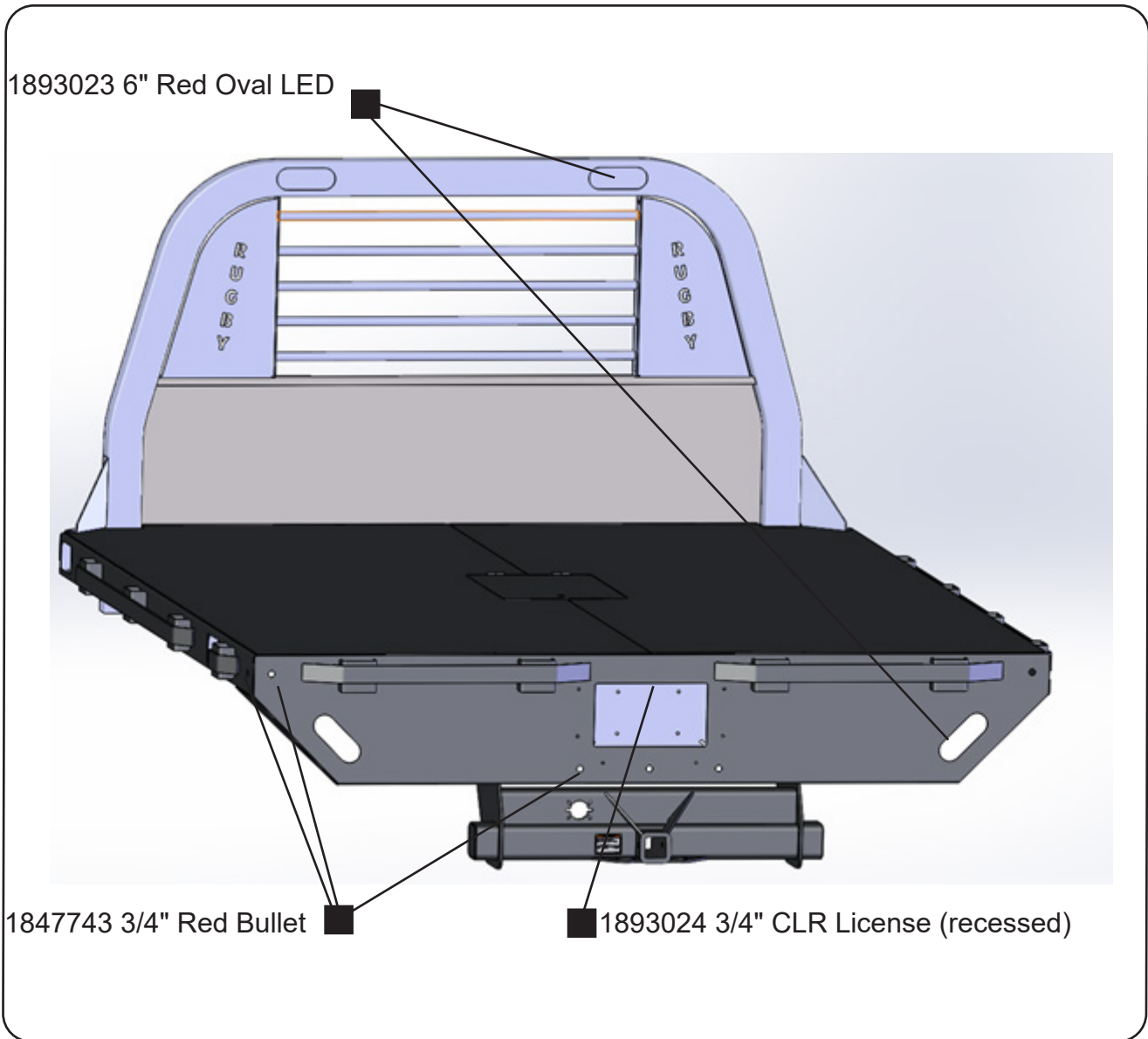

# Rugby Manufacturing Rancher Manual

---

## Maintenance & Operation

**NOTE:** Follow good safety practices and be aware of your surroundings when operating this product. Read and follow the general warnings found at the beginning of this manual.

**NOTE:** If a receiver hitch is included with the Rancher body, the Maximum Gross Trailer Weight is 20,000 lbs with a Maximum Vertical Tongue Load of 2,000 lbs. Never exceed towing capacity of the vehicle, receiver hitch, or any part of towing system.

**NOTE:** The gooseneck Maximum Gross Trailer Weight for the Rancher body with a gooseneck compartment is 30,000 lbs. The rated vertical coupler load (tongue weight) is 7,500 lbs. This will be reduced if any other component of the towing system has a lower rating. If the truck, gooseneck ball, safety chains, trailer components, etc are rated lower than 30,000 lbs, the lowest rating should be used to determine the Maximum Gross Trailer Weight of the complete setup.

**WARNING:** Overloading of a vehicle can cause vehicle component damage or an accident which may cause injury or death. Never exceed the gross vehicle weight (GVWR) or the gross axle weight (GAWR) rating or gross combined vehicle rating (GCWR) of your vehicle.

**FASTENERS:** Check that all bolts and nuts securing the body to the frame are tight. Check these every time the vehicle is serviced, or at least once a year. Initially recheck these within 1 month after the body is installed. The 5/8" bolts should be tightened to 60-65 ft-lbs of torque.

**Lighting:** Inspect the lighting periodically for proper operation. Replace or repair any damaged wiring, broken lenses, broken bulbs, or burnt out bulbs. Proper lighting is critical to the safe operation of the vehicle. Install the lights as shown in [Figure 3](#), and then attach wiring harness

**Decals:** Decals must be present and readable on the body. If any decals are missing or damaged, they must be replaced. To obtain replacement decals, contact your "Rugby" dealer.

**WARNING:** Missing or damaged decals can lead to accidents that may cause serious injuries or death.