

Rugby Manufacturing Hoist Cylinder Bulletin

Preface Technical Service Bulletin



This bulletin applies to the following hoist models:

<i>LR-310</i>	<i>LR-165</i>	<i>LR-26B</i>	<i>LR-2066</i>	<i>HR-550</i>	<i>TH-522</i>	<i>TB-16</i>
<i>LR-3510</i>	<i>LR-165A</i>	<i>LR-26C</i>	<i>LR-2355</i>	<i>TH-3512</i>	<i>TB-12</i>	<i>TH-650</i>
<i>LR-3510A</i>	<i>LR-25</i>	<i>LR-27B</i>	<i>LR-2866A</i>	<i>TB-8</i>	<i>TH-544</i>	<i>TB-18</i>
<i>LR-416</i>	<i>LR-25A</i>	<i>LR-623</i>	<i>HR-520</i>	<i>TH-410</i>	<i>TB-14</i>	<i>TH-660</i>
<i>LR-416B</i>	<i>LR-525</i>	<i>LR-28A</i>	<i>HR-540</i>	<i>TB-10</i>	<i>TH-5550</i>	<i>TB-20</i>

Toll Free: 1-800-869-9162 • Office: 1-701-776-5722 • Fax: 1-701-776-6235

Visit www.rugbymfg.com for further information.

Rugby Manufacturing Hoist Cylinder Bulletin

Table of Contents

Cylinder Identification	3
Cylinder Seal Repair	6
Cylinder Disassembly & Seal Removal.....	6
Seal Installation & Cylinder Assembly.....	7



Rugby Manufacturing Hoist Cylinder Bulletin

Cylinder Identification

When ordering replacement parts, it is necessary to determine what cylinder you have. Use the following steps and charts to select the correct seal kit item number.

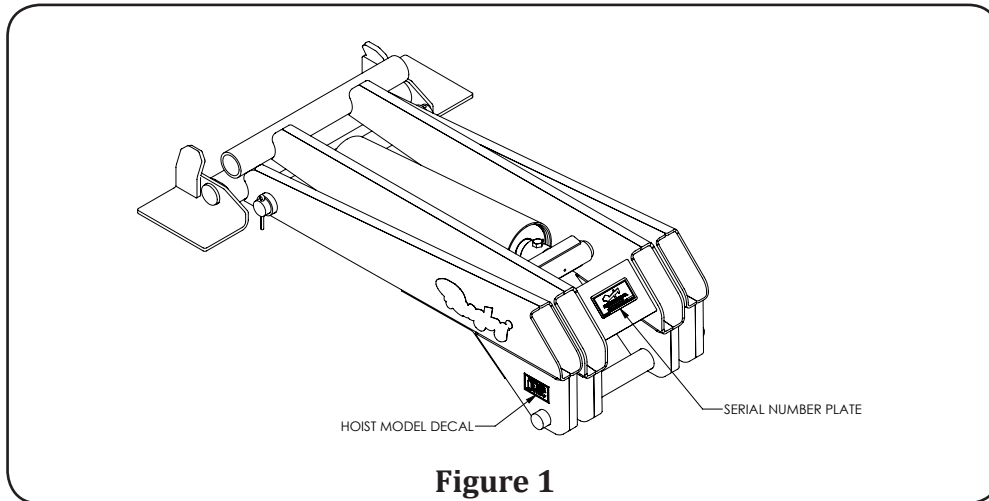

Figure 1

1. Determine the model of the hoist you are repairing by referencing the hoist model decal (**Figure 1**). If the decal is missing or damaged, contact Rugby Manufacturing with the serial number to determine the model.

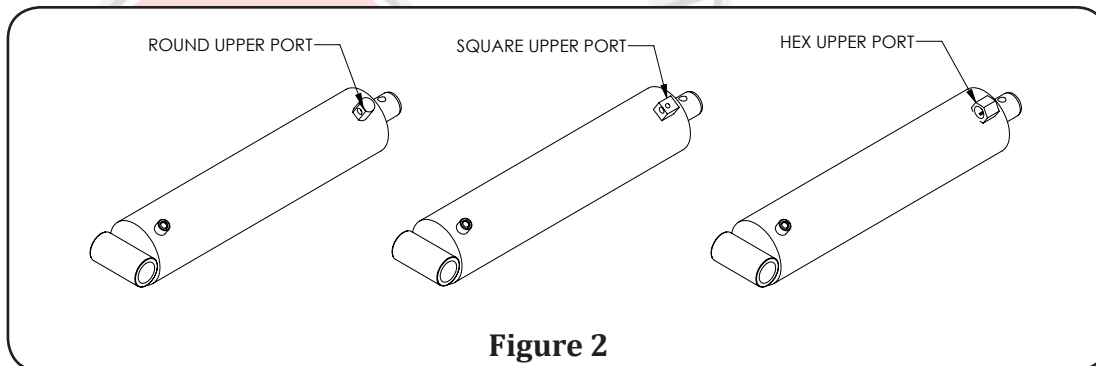

Figure 2

2. Determine whether the port at the rod end of the cylinder is round, hexagonal or square shaped (**Figure 2**). This is referred to as the upper port style and is needed to identify the correct seal kit.

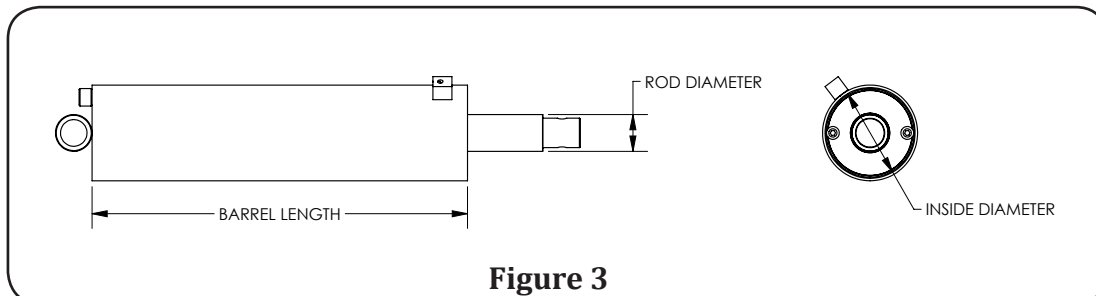

Figure 3

3. LR-26B and LR-2066 models with a round port cylinder require the rod diameter measurement as well. If the rod is necked down at the end, measure the larger diameter after the necked down feature (**Figure 3**).

Rugby Manufacturing Hoist Cylinder Bulletin

Cylinder Identification cont.

Hex Port Style

Build dates prior to 2/2002

Hoist Model	Seal Kit #	Cylinder Part #	Rod Dia.	Inside Dia.	Stroke Length	Barrel Length
LR-310	1656161	1656155	1.5"	3"	10"	14.56"
LR-3510	1656162	1621263	1.5"	3.5"	10"	14.56"
LR-416	1656160	1667217	2"	4"	16"	21"
LR-165	1656152	1656145	2"	5"	16"	21.25"
HR-520	1656152	1621474	2"	5"	16"	21.25"
LR-25	1656152	1621258	2"	5"	20"	25.25"
HR-540	1656152	1312235	2"	5"	20"	25.25"
LR-2355	1656152	1621262	2"	5"	23"	28.25"
LR-525	1656152	1655266	2"	5"	25"	30.33"
LR-26B old LR-2066 old	1656158	1656151	2"	6"	20"	25.68"
LR-28A LR-2866A	1656156	1656149	2.5"	6"	28"	33.33"
LR-27B	1656163	1667266	2"	7"	20"	25.68"

Figure 4

Hex Port Style (Figure 4)

Round Port Style

Build dates 2/2002-1/2010

Hoist Model	Seal Kit #	Cylinder Part #	Rod Dia.	Inside Dia.	Stroke Length	Barrel Length
LR-3510 TH-3512/TB-8	1656169	1621263	1.5"	3.5"	10"	14.56"
LR-416	1656170	1315035	2"	4"	16"	21"
LR-416B TH-410/TB-10	1656170	1621265	2"	4"	16"	21"
LR-165	1656171	1656145	2"	5"	16"	21.25"
HR-520 TH-522/TB-12	1656171	1621474	2"	5"	16"	21.25"
LR-25	1656171	1621258	2"	5"	20"	25.25"
HR-540	1656171	1312235	2"	5"	20"	25.25"
LR-2355	1656171	1621262	2"	5"	23"	28.25"
TH-544/TB-14	1657017	1621269	2.25"	5"	21"	26.25"
HR-550	1657023	1315043	2.25"	5.5"	20"	25.62"
LR-26B old LR-2066 old	1656172	1656151	2"	6"	20"	25.68"
LR-26B current LR-2066 current	1656173	1621268	2.5"	6"	20"	25.68"
TH-5550/TB-16	1656173	1621266	2.5"	6"	19"	24.33"
LR-623 TH-650/TB-18	1656173	1621264	2.5"	6"	23"	28.33"
LR-28A LR-2866A	1656173	1656149	2.5"	6"	28"	33.33"
TH-660/TB-20	1657019	1656788	2.75"	6"	29"	34.33"
LR-27B	1657020	1667266	2"	7"	20"	25.68"

Figure 5

Round Port Style (Figure 5)

Rugby Manufacturing Hoist Cylinder Bulletin

Cylinder Identification cont.

Square or Round Port Style

Build dates after 1/2010

Hoist Model	Seal Kit #	Cylinder Part #	Rod Dia.	Inside Dia.	Stroke Length	Barrel Length
LR-3510 TH-3512/TB-8	1694945	1621263	1.5"	3.5"	10"	14.56"
LR-416B TH-410/TB-10	1621272	1621265	2"	4"	16"	21"
HR-520 TH-522/TB-12 LR-165A	1621273	1621474	2"	5"	16"	21.25"
HR-540	1621273	1312235	2"	5"	20"	25.25"
LR-2355	1621273	1621262	2"	5"	23"	28.25"
TH-544/TB-14 LR-25A	1621274	1621269	2.25"	5"	21"	26.25"
HR-550		1315043	2.25"	5.5"	20"	25.62"
LR-26B LR-26C LR-2066	1621275	1621268	2.5"	6"	20"	25.68"
TH-5550/TB-16	1621275	1621266	2.5"	6"	19"	24.33"
LR-623 TH-650/TB-18	1621275	1621264	2.5"	6"	23"	28.33"
LR-28A LR-2866A	1621275	1621270	2.5"	6"	28"	33.33"
TH-660/TB-20	1621276	1656788	2.75"	6"	29"	34.33"
LR-27B		1667266	2"	7"	20"	25.68"

Figure 6

Square or Round Port Style (Figure 6)

Note: Verify barrel length measurements and/or build dates before selecting seal kit. Round port style cylinders manufactured after 1/2010 require the same seal kit # as cylinders with the square port style.

Rugby Manufacturing Hoist Cylinder Bulletin

Cylinder Seal Repair

Cylinder Disassembly & Seal Removal

The following steps are a guideline for disassembling a cylinder to replace seals.

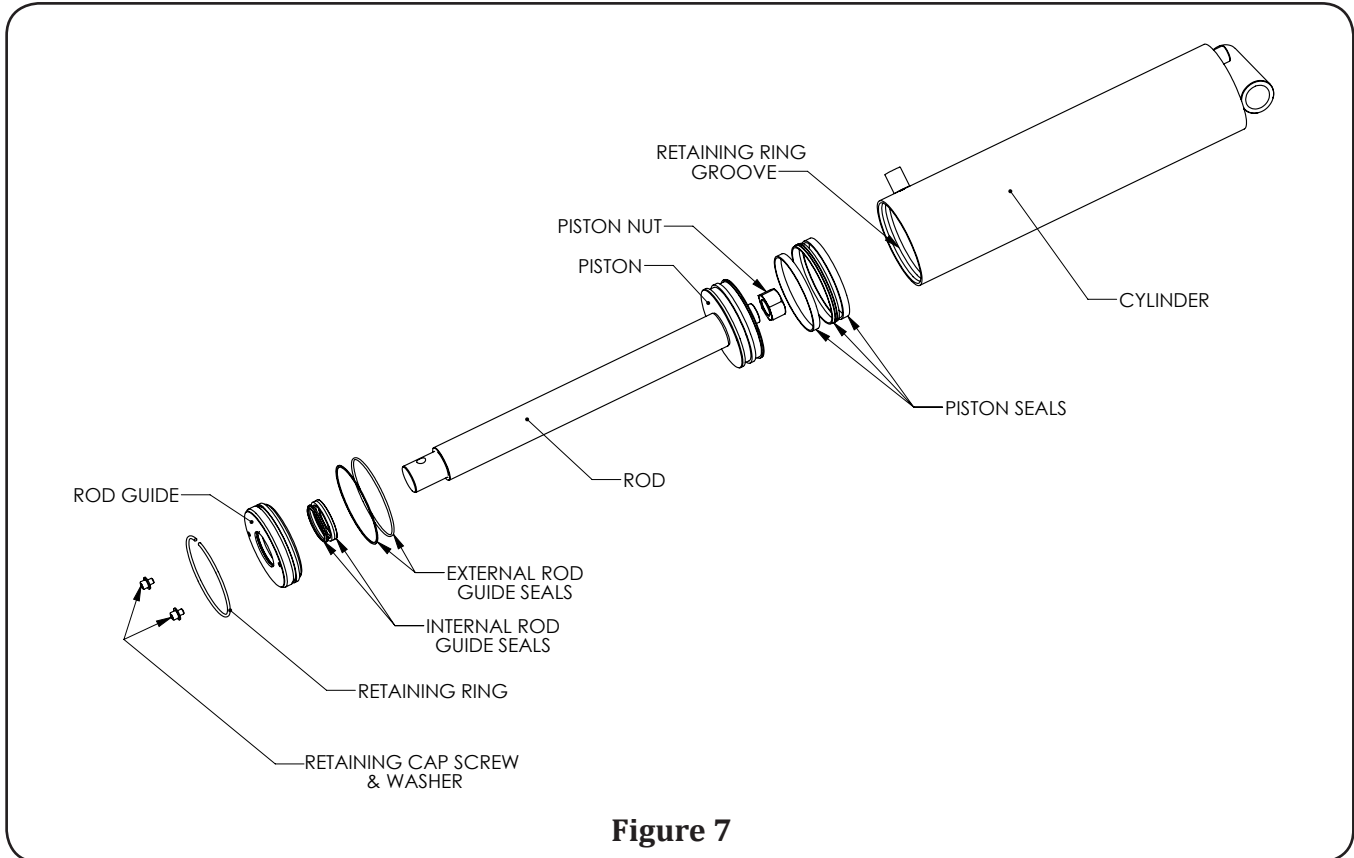

Figure 7

1. Remove cylinder from hoist frame. The cylinder should be disassembled in a clean environment to prevent dirt or other contamination from entering the interior of the cylinder. No special tools are required for disassembly. Items that should be at hand are a vise, flat punch, hammer, emery cloth, clean oil, clean paper towels or shop towels and wrenches for removal of the guide retaining cap screws and the piston nut.
2. Clean any accumulated dirt or debris from the port openings and rod guide area. Remove the port plugs and drain any oil from the cylinder. Do not reinstall the port plugs at this time.
3. Remove the two rod guide retaining Cap Screws and washer that are installed in the face of the rod guide.
4. After removing the guide retaining Cap Screws, secure the cylinder in a vise at about the mid-point of the wall. Do not excessively tighten vise on wall or it will be difficult to pull piston past deflected area of wall. Place the punch on the face of the rod guide and gently tap on the punch with the hammer to drive the rod guide into the cylinder bore. Drive the rod guide inside the bore until the front face of the rod guide is just past the retaining ring. Use fingers to remove retaining ring from groove in wall. A screwdriver can be used to lift the retaining ring out of the groove also. Be very careful to not scratch any part of the cylinder bore as a scratch may damage the piston seal upon assembly.

Rugby Manufacturing Hoist Cylinder Bulletin

Cylinder Seal Disassembly cont.

5. Use the emery cloth to remove any burrs that are present along the retaining ring groove in the cylinder bore. This will make it easier to remove the rod guide and piston, and help prevent damage to the seals when re-installing.
6. Pull the rod vigorously outward and allow the piston to bump the rod guide. If there is high resistance to piston movement in the area of the vise jaws, the vise is probably too tight. The momentum of the rod should be sufficient to pull the rod guide and piston from the cylinder barrel. Be careful not to mar the chromed surface of the rod.

Note: The piston seal and the rod guide static seal will likely be cut by the edge of the retaining ring groove on removal from the barrel. This is normal and cannot be avoided on disassembly. The nut does not need to be removed unless there are indications that the seals between the rod and piston are leaking. These do not normally wear out.

7. Loosen and remove the piston nut and piston.
8. Remove the rod guide from the rod. Do not remove the seals from the head gland and piston at this time.
9. Check the cylinder tube for scoring. If small nicks are present the tube can be repaired by honing. If serious scoring is present, the tube must be replaced.
10. Change the hydraulic oil in the system, and clean and check all parts for wear. Replace parts if necessary.
11. Note the position and orientation of the seals on the piston and rod guide before replacing them. Be careful to not scratch the seal grooves when removing the old seals. The seals can be removed with a sharp tool like an awl by carefully pushing the point partially into the seal and prying the seal from the groove. Hard seals can be removed by carefully cutting the seal apart with a utility knife or an x-acto knife.

Seal Installation & Cylinder Assembly

The following steps are a guideline for installing new seals and re-assembling the cylinder.

Note: The seal kit you receive will have the necessary seals for your cylinder, but may have extra seals depending on the exact cylinder you have. The best way to insure that the proper seals are used and installed correctly is by removing one old seal and immediately replacing it with a new seal of the same size. This procedure is then repeated until all seals are replaced.

1. Inspect the seal grooves and clean away any contamination. Apply a light coating of clean oil to the new seals and into the seal grooves to ease installation and prevent scuffing of the sealing surfaces.
2. Assemble the rod guide and piston onto the rod. Install and tighten the piston nut to the required torque.
3. Apply a light coating of clean oil to the piston and guide OD and to the mouth of the cylinder barrel. Carefully position the piston so that it is centered and square with the cylinder wall mouth. Once started, push firmly until the piston is about half way down the length of the cylinder bore. Carefully push the rod guide into the cylinder bore until the front face of it clears the retaining ring groove. Be careful to not mar the chromed rod surface. Install the rod-guide retaining ring into the groove and be certain that it is completely nested into the bottom of the groove. Pull the rod outward until the piston contacts the rod guide. Continue to pull on the rod until the rod

Rugby Manufacturing Hoist Cylinder Bulletin

Seal Installation & Cylinder Assembly cont.

guide is firmly in position against the retaining ring. Install rod guide retaining cap screws and washers. Tighten 5/16" cap screws to 33ft-lbs. Tighten 3/8" cap screws to 37ft-lbs.

4. Check cylinder for external leaks using rated hydraulic pressure. Any leaks should be evident after the cylinder has been pressurized for one minute. Remove pressure from cylinder. If the seals are oil tight, the cylinder is ready for service.



Keep away from jets of high-pressure oil. High pressure oil jets can penetrate skin and cause severe injury or death.

5. Re-install cylinder into the hoist frame.

