



TRUCK BODIES & EQUIPMENT INTERNATIONAL, Inc.

Website: www.TBEI.com

E-mail: sales@TBEI.com

Phone: 1-866-899-9045

090002

MODEL TB-16/TH-5550, TB-18/TH-650, & TB-20/TH-660 TRAILER HOIST INSTALLATION AND OPERATION MANUAL

To Be Filled In By Installer

Hoist Serial #: _____

Pump Installation and
Operation Manual #: _____

In Service Date: _____

Dealer: _____

Address: _____

City, State ZIP: _____

Dealer Phone Number: _____

Use this manual *ONLY* if installing or operating a model TB-16/TH-5550, TB-18/TH-650, or TB-20/TH-660 hoist on a trailer application. This manual should be kept in the glove compartment of the truck pulling the trailer or any weatherproof compartment on the trailer for reference when needed.

Original Revision: June 8, 2006

Current Revision: D February 16, 2007

"MESSAGE TO THE TRAILER MFG"

This manual contains instructions on how to correctly install the hoist. These instructions are general as each trailer is manufactured differently. Trailer manufacturers should be aware of the following issues.

This manual does not outline the operation instructions of the hoist other than to give several general warnings. Operating instructions can be found in the manual included with the hydraulic systems available from TBEI. **It is important that the hydraulic system manual be included with this manual and made available to the end user of the trailer.**

Some trailer manufacturers buy and install a hydraulic system not from TBEI, or modify a hydraulic system supplied by TBEI. If you are in this category it is the responsibility of the trailer manufacturer to make or obtain the correct operation manual for the hydraulic system being used. **It is important that the hydraulic system manual be included with this manual and made available to the end user of the trailer.**

The decals supplied are general in nature and are for the use of the hoist. TBEI does not imply that these are the only decals required for the trailer you are manufacturing. Since the trailer you are manufacturing may be different, TBEI has no way of knowing what decals the trailer you manufacture requires, and so this must be the trailer manufacturer's responsibility. If for some reason the decals don't apply, or you require more decals, you, as the manufacturer, must **make sure** to change or add warnings and instructions and obtain the appropriate decals.

"HYDRAULIC SYSTEM"

The hydraulic system supplied with a given hoist manufactured by TBEI is made up of components (pump, valves, reservoir, hoses, cylinder, etc.) that are designated to be compatible with each other.

WARNING: If you substitute hydraulic components, it is your responsibility to **BE SURE** they are compatible with the other components supplied by TBEI. Incompatible hydraulic components may cause failure of the hoist that, in turn, could damage the vehicle, damage other property, and cause human injury or death.

All TBEI's liability and warranty for a given hoist will be voided, if it is determined by TBEI, that substituted hydraulic components were incompatible with those supplied by TBEI.

Several hoist parameters are given in the following table, these parameters are given as a general guide. To ensure component compatibility, consult TBEI.

| HOIST MODEL | TB-16, TH-5550, TB-18, TH-650, TB-20, or TH-660 |
|--|--|
| "MAXIMUM" HYDRAULIC FLOW RATE (GPM) | 9 GPM |
| "MAXIMUM" PRESSURE FOR RAISING PORTION OF DUMP CYCLE (PSI) | 3200 PSI |
| "MAXIMUM" PRESSURE FOR LOWERING PORTION OF DUMP CYCLE (PSI) | 1000 PSI |

"WARNINGS"

- WARNING:** Installing or operating this hoist without first understanding the proper installation and operation procedures can lead to serious injury or death. Always read and understand fully all installation and operation manuals before installing or operating this equipment.
- WARNING:** Welding, oxy-fuel cutting, or grinding sparks can cause fuel to ignite that in turn can lead to injury or death. **Always** take adequate steps to avoid ignition of fuel from fuel tanks when welding, grinding, or oxy-fuel cutting during equipment installation.
- WARNING:** Heat from the truck's exhaust system can cause hydraulic component failure and may lead to a fire that could cause injury or death. **Always** install equipment in locations where heat from the exhaust system will not damage any hydraulic component.
- WARNING:** Being under a raised body can result in serious injury or death should the body unexpectedly descend. **Never** position yourself or allow others to position themselves under a **loaded** body. **Always** prop the **unloaded** body up using the body prop or body props supplied. **Remember** body props are to be used only on an **unloaded** body. When two props are provided, both props must be used.
- WARNING:** Malfunctioning equipment can cause property damage, injury or death. **Always** have faulty equipment repaired before continuing its use. Consult the manufacturer if required.
- WARNING:** Overloading of a trailer can cause vehicle or trailer component damage or an accident which may cause injury or death. **Never** exceed the gross vehicle weight (GVW) or the gross axle weight (GAW) rating of your vehicle or trailer.
- WARNING:** The inadvertent shorting of the vehicle's electrical supply can cause a fire or equipment damage that could lead to injury or death. **Always** disconnect the vehicle battery prior to installing, servicing, or repairing the power unit.
- WARNING:** Damage to brake lines during equipment installation, or installing bolts or equipment in such a way that the line will rub and become damaged can lead to brake failure which can cause an accident and can lead to severe injury or death. **Always** take adequate steps to prevent brake line damage during installation and isolate brake lines from installed equipment.
- WARNING:** Connecting the hoist to a hydraulic system with more pressure (psi) or flow (gpm) than is recommended by the hoist manufacturer can cause the hoist to fail during the dumping of a load. This could lead to damage, serious injury, or death. **Be sure** you have the correct pressure and flow. Consult the trailer manufacturer if you do not know the recommended pressure and flow.

WARNING: Adjusting the hydraulic pressure to more than the recommended setting may cause the hoist to fail during the dumping of a load. This could cause damage, serious injury, or death. **Never** adjust the pressure on your own. Consult the trailer manufacturer if the hydraulic pressure is in question. Have only a qualified person set the hydraulic pressure. **Never** adjust the pressure to more than the recommended amount.

TABLE A TB-16 or TH-5550 TRAILER APPLICATION CHART

| BODY LENGTH | OVERHANG | CAPACITY 45° DUMP ANGLE | CAPACITY 50° DUMP ANGLE |
|-------------|----------|----------------------------|----------------------------|
| 14' | 12" | 11.7 TONS | 10.6 TONS |
| 14' | 18" | 12.8 TONS | 11.6 TONS |
| 14' | 24" | 14.1 TONS | 12.7 TONS |
| 16' | 12" | 10.1 TONS | 9.1 TONS |
| 16' | 18" | 10.8 TONS | 9.8 TONS |
| 16' | 24" | 11.7 TONS | 10.6 TONS |
| 18' | 24" | 10.1 TONS | 9.1 TONS |
| 18' | 30" | 10.8 TONS | 9.8 TONS |

TB-16 or TH-5550
DUMP CLASS: 50
CONVERSION CLASS: E

| STANDARD MOUNTING | |
|-------------------|--------|
| DUMP ANGLE | M |
| 45° | 90.25" |
| 50° | 81.75" |

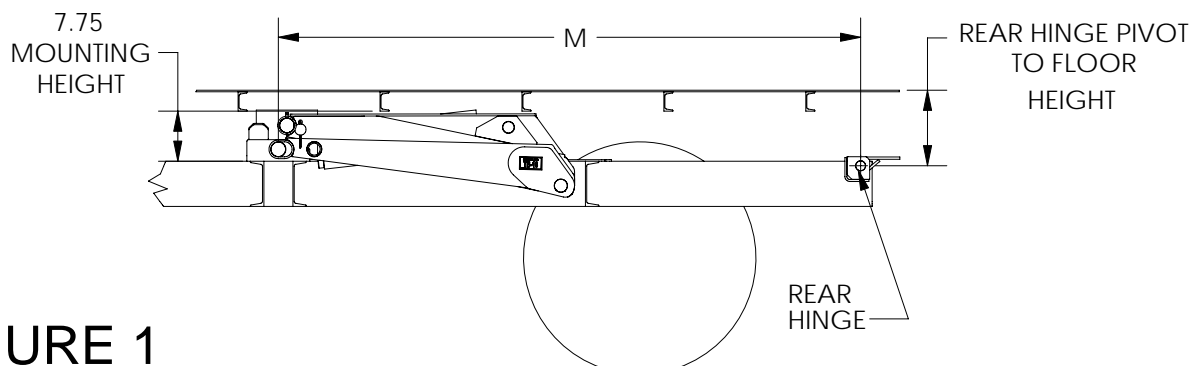

FIGURE 1

Capacities are based on the following:

1. Water level non-diminishing loads.
2. The vertical height between the rear hinge pivot and the floor is no less than 6.0”.
3. The hydraulic relief pressure set at the maximum 3,200 psi (see page 3 of this manual).
4. The material hauled has a density of no more than 3,500 lb/cubic yard.
5. The load is 8 ft. wide.

IMPORTANT: Because of variations in applications, the data contained in this sheet is provided only as a general guide.

TABLE A TB-18 or TH-650 TRAILER APPLICATION CHART

| BODY LENGTH | OVERHANG | CAPACITY 45° DUMP ANGLE | CAPACITY 50° DUMP ANGLE |
|-------------|----------|----------------------------|----------------------------|
| 16' | 12" | 12.3 TONS | 11.0 TONS |
| 16' | 18" | 13.2 TONS | 11.9 TONS |
| 16' | 24" | 14.3 TONS | 12.9 TONS |
| 18' | 12" | 10.7 TONS | 9.6 TONS |
| 18' | 18" | 11.5 TONS | 10.3 TONS |
| 18' | 24" | 12.3 TONS | 11.0 TONS |
| 18' | 30" | 13.2 TONS | 11.9 TONS |

TB-18 or TH-650
DUMP CLASS: 50
CONVERSION CLASS: E

| STANDARD MOUNTING | |
|-------------------|---------|
| DUMP ANGLE | M |
| 45° | 100.00" |
| 50° | 90.75" |

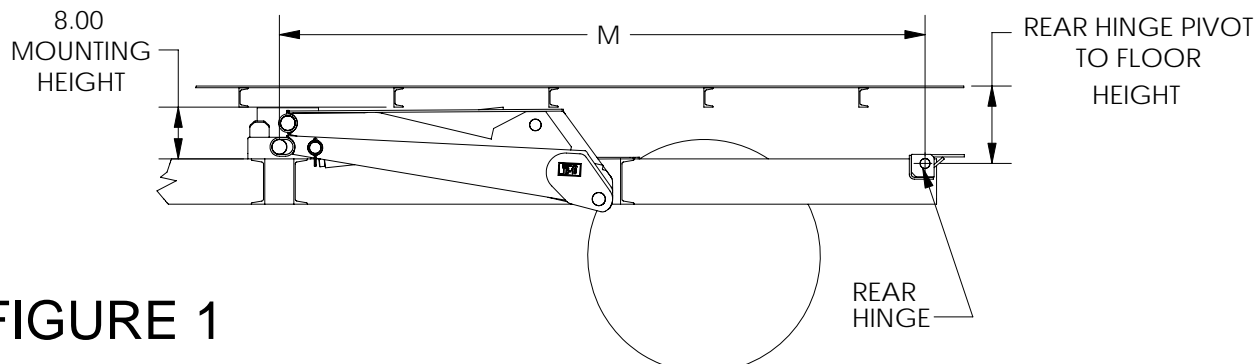

FIGURE 1

Capacities are based on the following:

1. Water level non-diminishing loads.
2. The vertical height between the rear hinge pivot and the floor is no less than 10.0”.
3. The hydraulic relief pressure set at the maximum 3,200 psi (see page 3 of this manual).
4. The material hauled has a density of no more than 3,500 lb/cubic yard.
5. The load is 8 ft. wide.

IMPORTANT: Because of variations in applications, the data contained in this sheet is provided only as a general guide.

TABLE A TB-20 or TH-660 TRAILER APPLICATION CHART

| BODY LENGTH | OVERHANG | CAPACITY 45° DUMP ANGLE | CAPACITY 50° DUMP ANGLE |
|-------------|----------|----------------------------|----------------------------|
| 18' | 12" | 12.4 TONS | 11.2 TONS |
| 18' | 18" | 13.2 TONS | 12.0 TONS |
| 20' | 18" | 11.7 TONS | 10.6 TONS |
| 20' | 24" | 12.4 TONS | 11.2 TONS |
| 22' | 12" | 9.9 TONS | 9.0 TONS |
| 22' | 18" | 10.4 TONS | 9.4 TONS |
| 22' | 24" | 11.0 TONS | 10.0 TONS |
| 22' | 30" | 11.7 TONS | 10.6 TONS |
| 24' | 12" | 9.0 TONS | 8.1 TONS |
| 24' | 18" | 9.4 TONS | 8.5 TONS |
| 24' | 24" | 9.9 TONS | 9.0 TONS |
| 24' | 30" | 10.4 TONS | 9.4 TONS |

TB-20 or TH-660
DUMP CLASS: 60
CONVERSION CLASS: F

| STANDARD MOUNTING | |
|-------------------|-------|
| DUMP ANGLE | M |
| 45° | 128.0 |
| 50° | 116.0 |

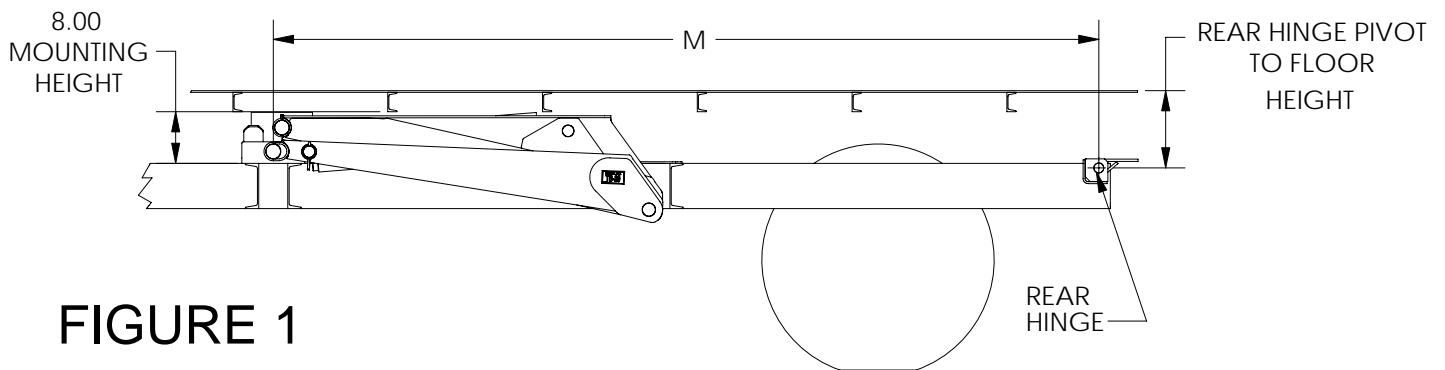

FIGURE 1

Capacities are based on the following:

1. Water level non-diminishing loads.
2. The vertical height between the rear hinge pivot and the floor is no less than 10.0”.
3. The hydraulic relief pressure set at the maximum 3,200 psi (see page 3 of this manual).
4. The material hauled has a density of no more than 3,500 lb/cubic yard.
5. The load is 8 ft. wide.

IMPORTANT: Because of variations in applications, the data contained in this sheet is provided only as a general guide.

"INSTALLATION INSTRUCTIONS"

NOTE: The following steps are to be used as a guideline when installing the TB-16/TH-5550, TB-18/TH-650, or TB-20/TH-660 hoist. Since trailers will vary according to their design, it is not possible to be specific about every aspect of the hoist installation.

1. Install the rear hinge. To be sure that the body will dump correctly, make sure the rear hinge is square with the trailer frame. The rear hinge must be supported by the trailer frame with sufficient strength to support the dumping of a load. Weld the rear hinge assembly to the trailer frame as indicated in Figure 2.

NOTE: The rear hinge Part# 03 1707 is illustrated in figure 2 and should be used when installing the TB-16/TH-5550, TB-18/TH-650, or TB-20/TH-660 hoist.

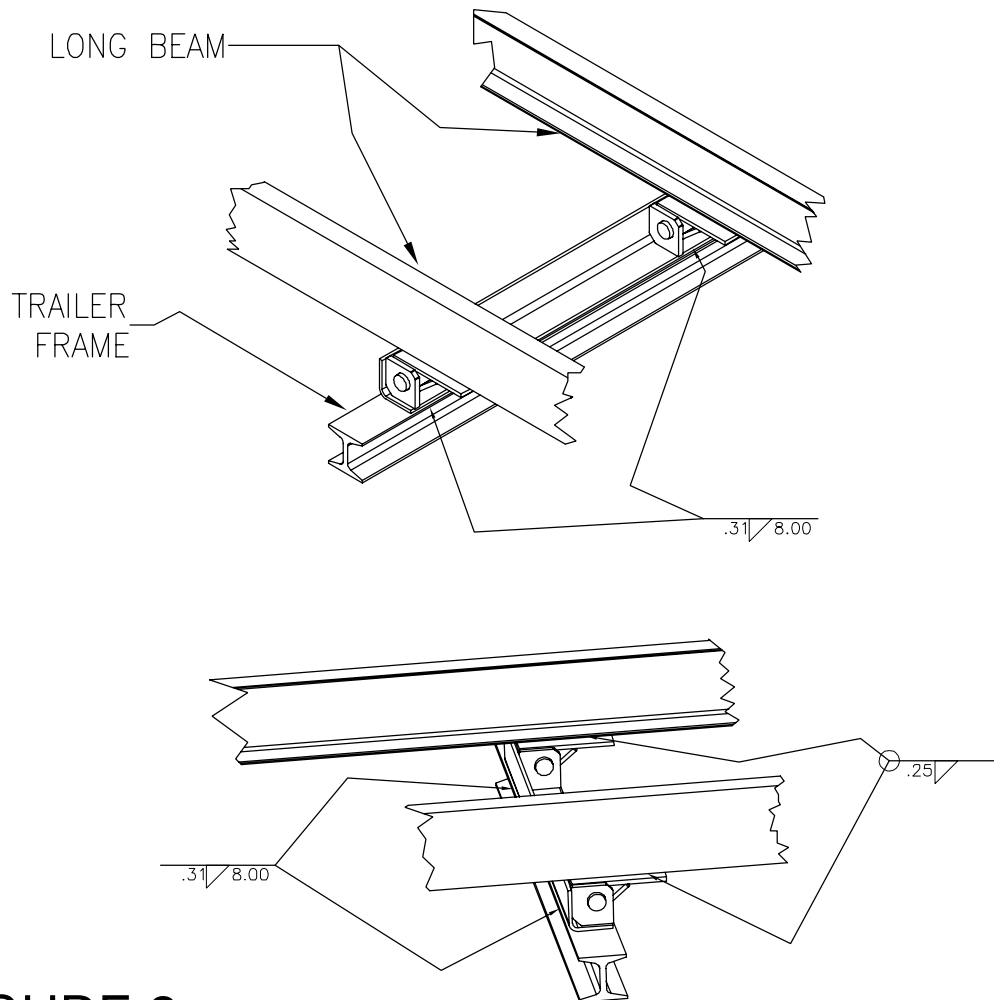
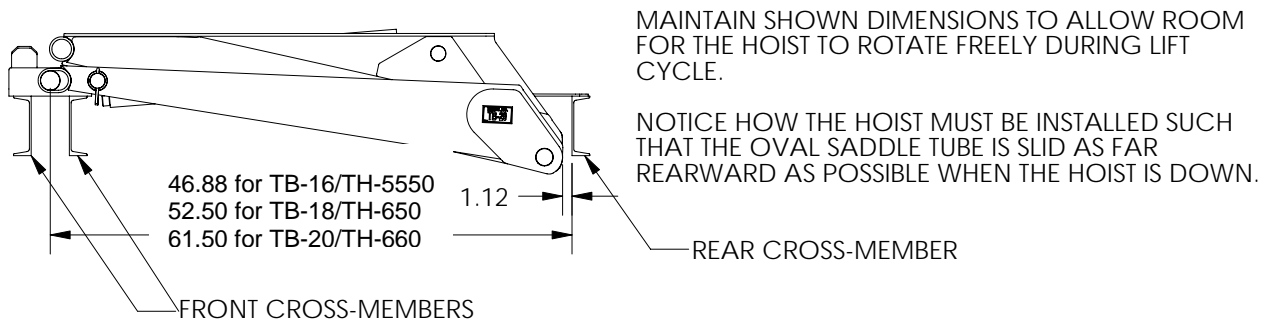

FIGURE 2

2. Install both the front and rear cross-members to support the hoist. The top of the front and rear cross-members should be at the same height. Refer to Figure 3.

FIGURE 3

HOIST POSITION BEFORE BEGINNING OF LIFT CYCLE



HOIST POSITION IN FIRST FEW DEGREES OF LIFT CYCLE

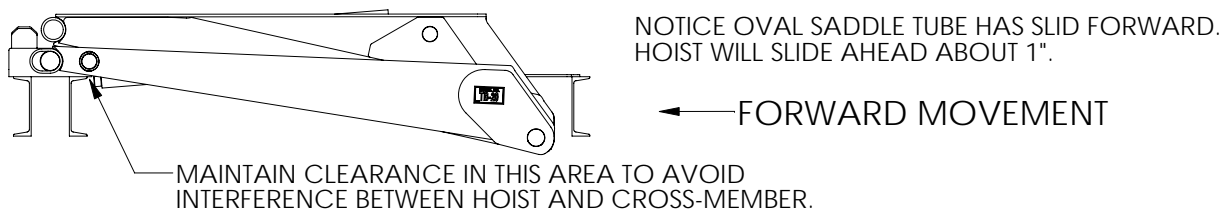

HOIST POSITION IN MIDDLE OF LIFT CYCLE

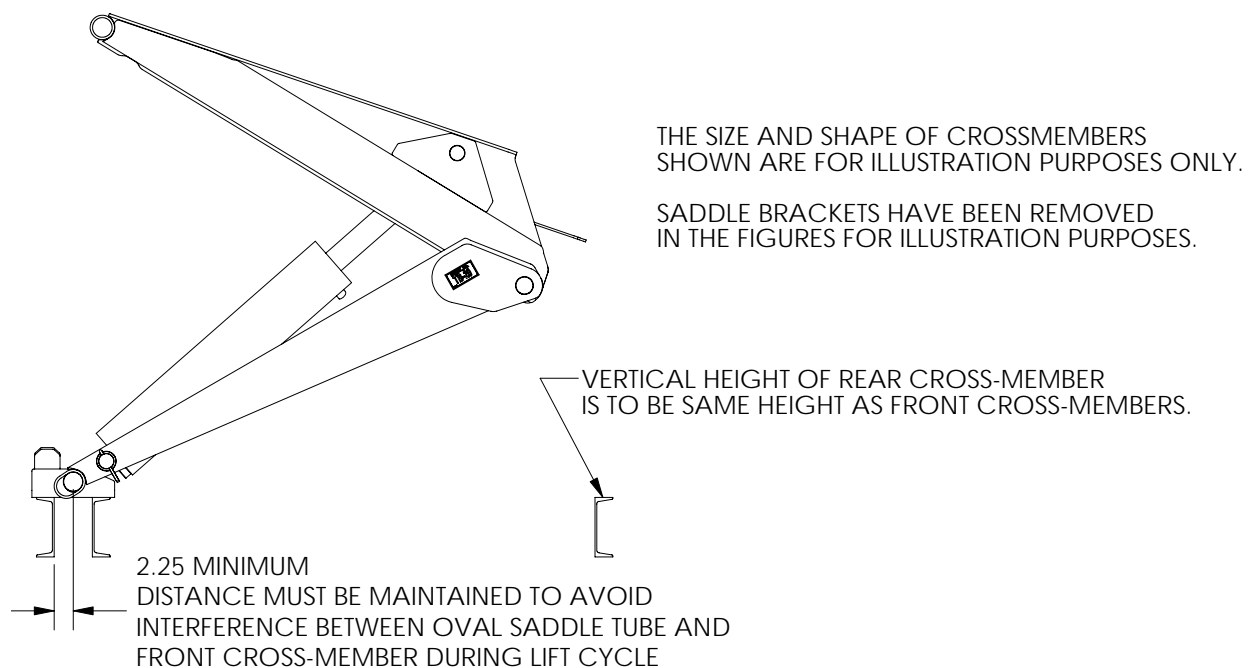

NOTE: The cross-members mentioned above are not supplied with the hoist, as they are part of the trailer design. For a given trailer, these cross-members must be of sufficient strength to support the hoist and any possible load that the cross-members will have on them during the dumping of the trailer.

3. Locate the hoist on the trailer frame, making sure to center the hoist left to right and to square the hoist with the trailer frame.

NOTE: The horizontal distance between the rear hinge center and saddle center (Figure 1) is referred to as the "M" dimension. In Table A the capacities for several applications and dump angles are tabulated for the different hoists.

NOTE: Moving the hoist in relation to the rear hinge will affect the hoist's performance. A forward movement of the hoist where the hoist is farther away from the rear hinge will reduce the dump angle and will increase capacity. A rearward movement of the hoist where the hoist is closer to the rear hinge will increase the dump angle and decrease capacity.

WARNING: Do not install the TB-16/TH-5550, TB-18/TH-650, or TB-20/TH-660 at a dump angle of less than 45° or more than 50°. The hoist is designed for this range. Installing the hoist outside of this range may lead to an unsafe condition that could cause hoist failure.

CAUTION: During the first few degrees of the dump cycle, the hoist lower link will move forward. It is important to keep the areas illustrated in Figure 3 open to allow for this movement. Failure to do this will cause the hoist to not operate as intended and may damage the hoist and/or other vehicle components.

4. When the hoist is positioned, weld or otherwise fasten each saddle bracket to the trailer cross-member as illustrated in Figure 4.

FIGURE 4

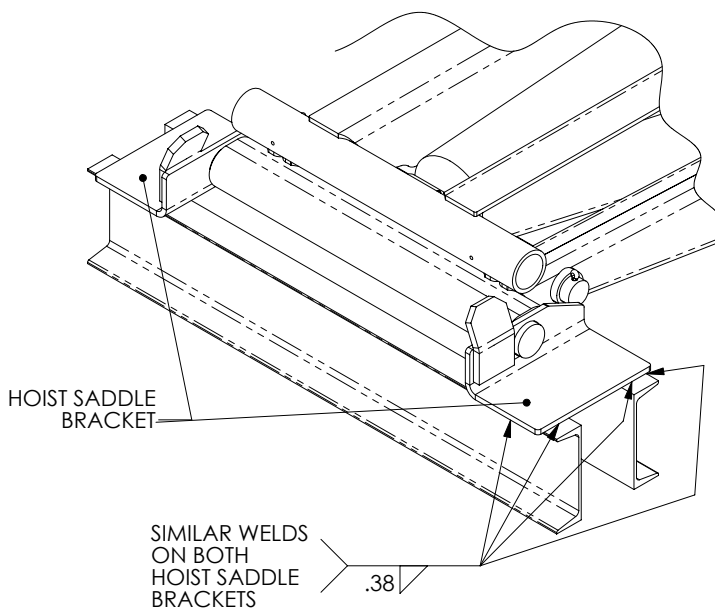

5. Slide a lock ring onto each lifting shaft. Slide a lifting shaft with lock ring into each end of the hoist lifting tube. See Figure 5.

FIGURE 5

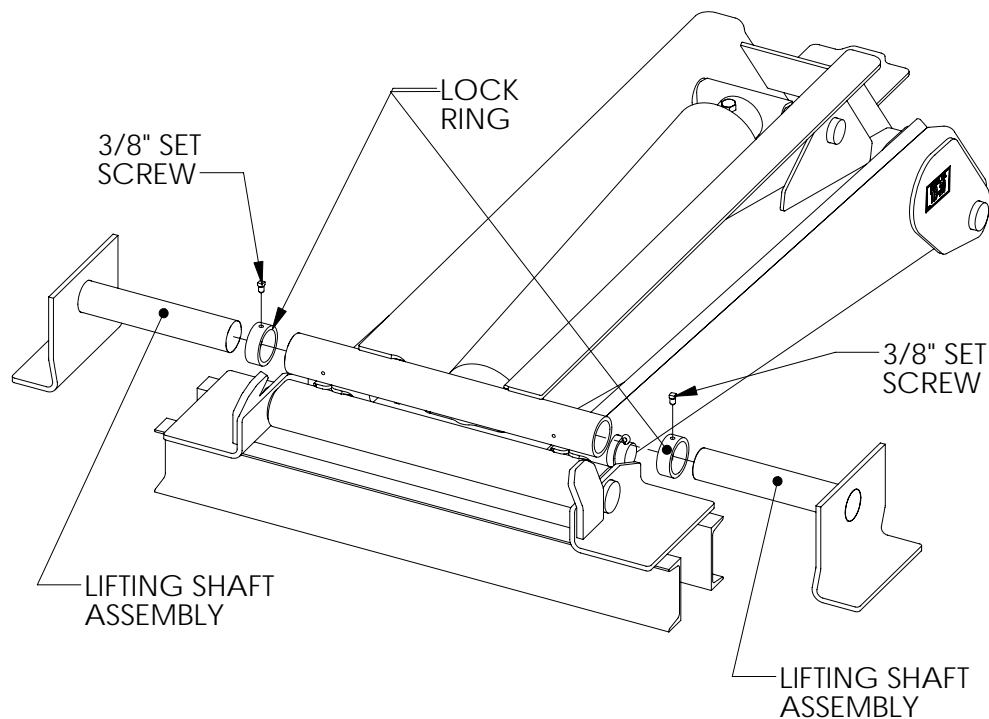

6. Position the body on the trailer frame and attach the trailer long beams to the rear hinge as shown in Figure 2. Weld the rear hinges to the long beams with at least as much weld as is indicated in Figure 2.

NOTE: The TB-16/TH-5550 hoist requires at least 7.75" of vertical clearance between the point where the saddle brackets mount to the cross-member and the trailer floor cross-members.

NOTE: The TB-18/TH-650 & TB-20/TH-660 hoists requires at least 8.0" of vertical clearance between the point where the saddle brackets mount to the cross-member and the trailer floor cross-members.

7. Once the trailer body is positioned on the trailer frame, slide each of the lifting shafts all the way out against the trailer body long beams. Weld each of two lifting shaft assemblies to each body long sill as illustrated in Figure 6.

8. With the lifting shafts secured, slide the lock rings against the hoist lifting tube and lock them in position by tightening the setscrew. Refer to Figure 5. Torque the setscrew to 24 ft-lb.

FIGURE 6

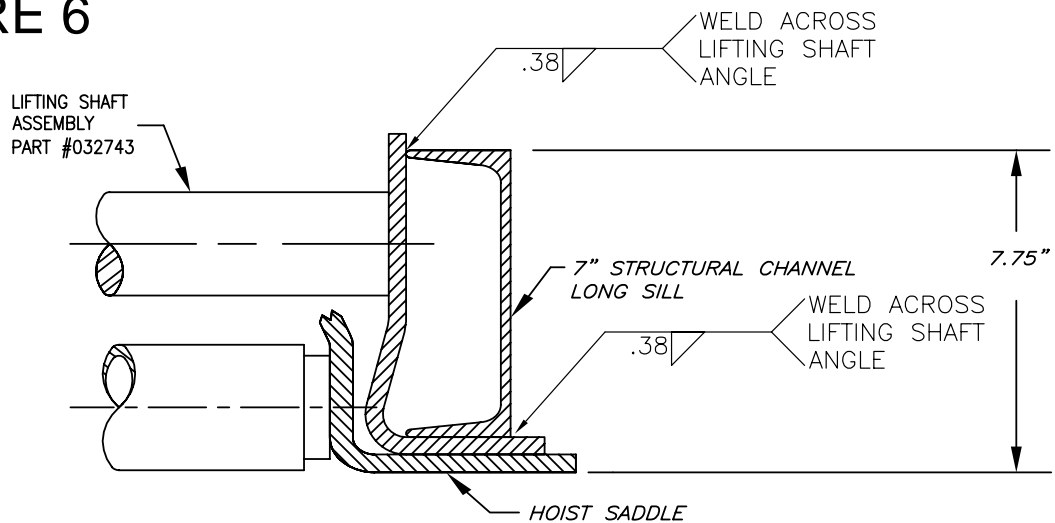

HOIST TO BODY ATTACHMENT DETAIL FOR 7" STRUCTURAL CHANNEL LONG SILLS AND 7.75" MOUNTING HEIGHT.

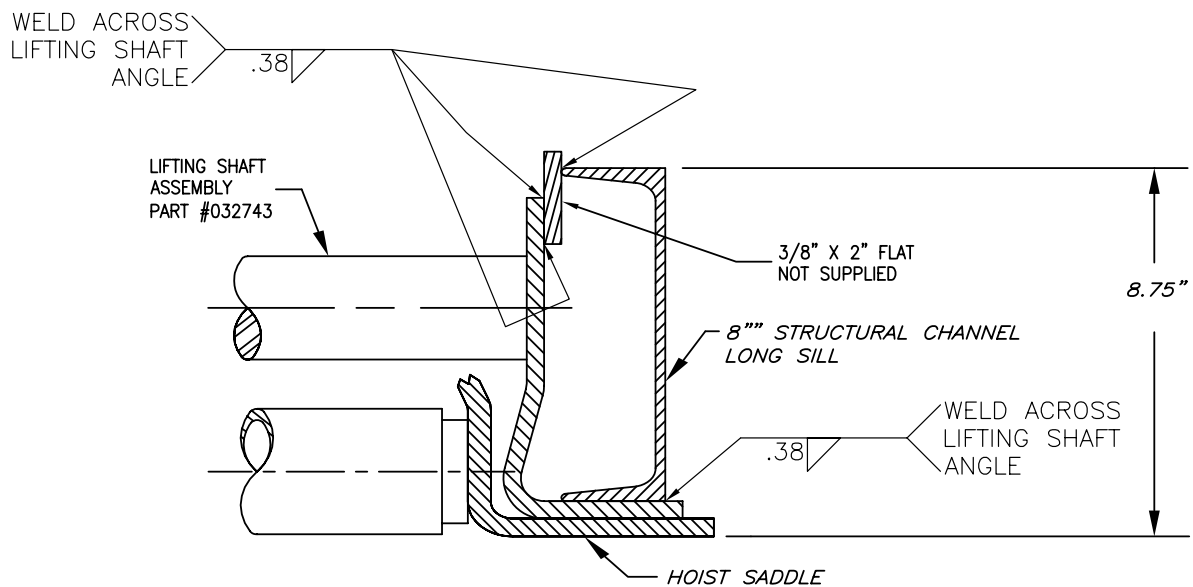

HOIST TO BODY ATTACHMENT DETAIL FOR 8" STRUCTURAL CHANNEL LONG SILLS AND 8.75" MOUNTING HEIGHT.

9. Install all grease fittings. For grease fitting locations in the hoist, refer to Figure 10. Torque each grease fitting to 70 in-lb. Grease all grease fittings on both the hoist and the rear hinge.
10. Install the body prop. Refer to the "**BODY PROP**" section of this manual.
11. Install the hydraulic system.

IMPORTANT: Several different types of hydraulic components are used to power the TB-16/TH-5550, TB-18/TH-650, or TB-20/TH-660 hoist. All hydraulic systems supplied by TBEI have an installation and operation manual included with them. For installation and operation information, refer to the Installation and Operation Manual for your particular hydraulic components. **BE SURE** to read and understand this manual and the installation and operating instructions included with the hydraulic system before you attempt to operate the TB-16/TH-5550, TB-18/TH-650, or TB-20/TH-660 hoist.

WARNING: Installing or operating this hoist without first understanding the proper installation and operation procedures can lead to serious injury or death. Always read and understand fully all installation and operation manuals before installing or operating this equipment.

12. Place a complete operation manual in the glove compartment of the truck that will pull the trailer, or in a place on the trailer that is sheltered from the weather and other elements. This manual **MUST BE** available for reference by the operator when needed.

WARNING: If the hydraulic system used to power the TB-16/TH-5550, TB-18/TH-650, or TB-20/TH-660 was supplied by TBEI, an operation manual will be included with the hydraulic components. The operation manual for this hydraulic system **MUST BE** supplied to the operator.

WARNING: If the hydraulic system used to power the TB-16/TH-5550, TB-18/TH-650, or TB-20/TH-660 was supplied by someone other than TBEI, an operation manual for this hydraulic system **MUST BE** obtained and supplied to the operator.

13. Install all decals. Refer to "**DECAL LOCATION**" section of this manual.

"BODY PROP"

NOTE: In order to comply with paragraph 10 of Federal Regulation #1926.601, all TBEI hoists will be sold with one body prop. It is the responsibility of the installer to determine whether one body prop is sufficient. The following information will help in making that determination.

The body prop is designed for use only when the body is empty. The purpose of the body prop is to hold an empty body in the raised position when performing maintenance or inspection on the hoist, body, or any component that requires working under an **empty** body.

Some applications may require 2 or more body props to support the **empty** body. To determine how many body props your application requires, refer to the following information.

WARNING: Being under a raised body can result in serious injury or death should the body inadvertently descend. **Never** position yourself or allow others to position themselves under a **loaded** body. **Always** prop the **unloaded** body up using the body prop/s supplied. **Remember**, body props are to be used only on an **unloaded** body. When two props are provided, both props must be used.

WARNING: Do not use body prop to support a loaded body!

WARNING: Do not perform maintenance under a raised body without first blocking the empty body up with the body prop/s.

WARNING: Do not use a body prop that is bent or otherwise damaged. A damaged body prop will have a reduced holding capacity, and may break when used to hold up the body. This could cause serious injury or death. Replace a damaged body prop before using it.

WARNING: Be sure to install the body prop according to the "**INSTALLATION OF BODY PROP**" section of this manual.

The following is a step-by-step procedure to determine how many body props are required for this application.

1. The TBEI Part Number 03 0703 body prop is to be used with the TB-16/TH-5550, TB-18/TH-650, or TB-20/TH-660 hoist. Determine if this is the body prop you have by referring to Figure 7.
2. Determine the "P" value referring to Figure 8. The "P" value is the horizontal distance between the rear hinge and the prop.

3. Determine the "X" value referring to Figure 8. The "X" value is the horizontal distance between the body center of gravity and the rear hinge when the body is empty and down. Be sure to include any items attached to the body such as toolboxes or other structures when determining the center of gravity.

FIGURE 7

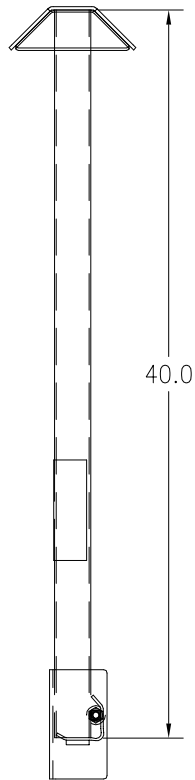

03 0703 Body Prop.
40" Tube.

FIGURE 8

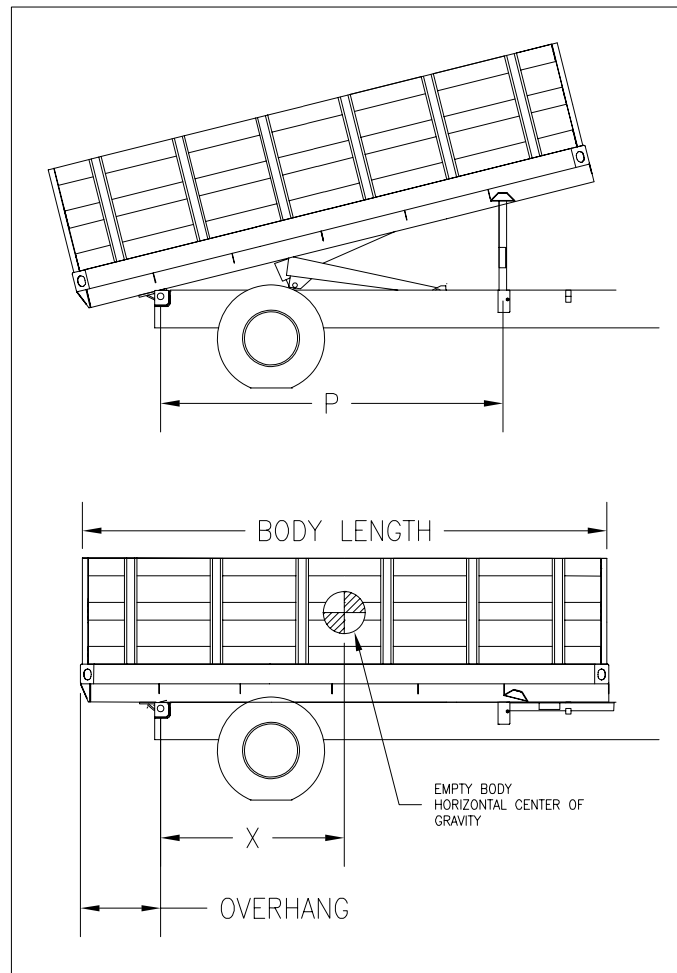

4. On the left side of Chart 1, pick the "P" value that is equal to the "P" value for your application. On the top of the same chart, pick the "X" value that is equal to the "X" value for your application. Below the "X" value and to the right of the "P" value is listed an amount of weight. This represents the maximum weight that the body can weigh and be supported by only one body prop. If the body weighs more than the amount listed, 2 body props will be required. Contact TBEI to order another body prop.

NOTE: If the body weighs more than 2 times the amount listed, another type of body prop with more weight capacity will be required, as 2 body props will not support this empty body.

CHART 1

03 0703 BODY PROP CAPACITY

| Maximum Body Weight per Body Prop | | | | | | | | | | | |
|-------------------------------------|---------|---|--------|-------|-------|-------|-------|--------|---------|---------|---------|
| | | Distance Rear Hinge - Center of Gravity (X) | | | | | | | | | |
| | | 0-36 | 37-48 | 49-60 | 61-72 | 73-84 | 85-96 | 97-108 | 109-120 | 121-132 | 133-144 |
| Distance Rear Hinge - Body Prop (P) | 42-47 | 6,100 | 4,500 | 3,500 | 2,800 | 2,300 | 2,000 | 1,700 | 1,500 | 1,300 | 1,100 |
| | 48-53 | 6,600 | 4,800 | 3,800 | 3,000 | 2,500 | 2,100 | 1,800 | 1,600 | 1,400 | 1,200 |
| | 54-59 | 7,200 | 5,200 | 4,100 | 3,300 | 2,800 | 2,300 | 2,000 | 1,800 | 1,600 | 1,400 |
| | 60-65 | 7,700 | 5,700 | 4,400 | 3,600 | 3,000 | 2,600 | 2,200 | 1,900 | 1,700 | 1,500 |
| | 66-71 | 8,300 | 6,100 | 4,800 | 3,900 | 3,300 | 2,800 | 2,400 | 2,100 | 1,900 | 1,700 |
| | 72-77 | 8,900 | 6,600 | 5,100 | 4,200 | 3,500 | 3,000 | 2,600 | 2,300 | 2,000 | 1,800 |
| | 78-83 | 9,500 | 7,000 | 5,500 | 4,500 | 3,800 | 3,200 | 2,800 | 2,500 | 2,200 | 2,000 |
| | 84-89 | 10,200 | 7,500 | 5,900 | 4,800 | 4,000 | 3,500 | 3,000 | 2,700 | 2,400 | 2,100 |
| | 90-95 | 10,800 | 7,900 | 6,200 | 5,100 | 4,300 | 3,700 | 3,200 | 2,800 | 2,500 | 2,300 |
| | 96-101 | 11,400 | 8,400 | 6,600 | 5,400 | 4,600 | 3,900 | 3,400 | 3,000 | 2,700 | 2,400 |
| | 102-107 | 12,100 | 8,900 | 7,000 | 5,800 | 4,900 | 4,200 | 3,700 | 3,200 | 2,900 | 2,600 |
| | 108-115 | 12,700 | 9,400 | 7,400 | 6,100 | 5,100 | 4,400 | 3,900 | 3,400 | 3,100 | 2,800 |
| | 114-119 | 13,400 | 9,900 | 7,800 | 6,400 | 5,400 | 4,700 | 4,100 | 3,600 | 3,200 | 2,900 |
| | 120-125 | 14,000 | 10,400 | 8,200 | 6,700 | 5,700 | 4,900 | 4,300 | 3,800 | 3,400 | 3,100 |
| | 126-131 | 14,700 | 10,900 | 8,600 | 7,100 | 6,000 | 5,200 | 4,500 | 4,000 | 3,600 | 3,300 |
| | 132-137 | 15,300 | 11,400 | 9,000 | 7,400 | 6,300 | 5,400 | 4,700 | 4,200 | 3,800 | 3,400 |
| 138-143 | 16,000 | 11,800 | 9,400 | 7,700 | 6,500 | 5,600 | 5,000 | 4,400 | 4,000 | 3,600 | |
| 144+ | 16,600 | 12,300 | 9,800 | 8,000 | 6,800 | 5,900 | 5,200 | 4,600 | 4,100 | 3,700 | |

EXAMPLE: Using a 12' body that has an empty weight of 6,000 pounds. Body is installed with a 18" overhang. The prop is located 84" forward of the rear hinge. Assume the center of gravity is 72" from the rear of the body. Subtract the overhang to get X=54". Using P=84", X=54", the maximum body weight is 5,900 pounds. This application needs 2 body props. **Remember,** this is an example only, and in no way means that the TB-16/TH-5550, TB-18/TH-650, or TB-20/TH-660 is or is not acceptable to use in this application.

"INSTALLATION OF BODY PROP"

NOTE: The following steps are to be used as a guideline when installing the body prop. Since trailers will vary according to their design it is not possible to be specific about every aspect of the body prop installation.

1. Once the TBEI hoist has been installed, raise the hoist up and temporarily block the body up. Position the prop assembly against the trailer frame as illustrated in Figure 9.
2. Fasten the body prop assembly base to the trailer frame.
3. Position and fasten the prop hanger to the trailer frame. Hanger must be installed so that when the body is down the body prop leg will not bounce out of the hanger.
4. Position and weld the prop cup on the body as illustrated in Figure 9.

NOTE: To raise and lower body prop, see the "**OPERATION OF BODY PROP**" section of this manual.

FIGURE 9

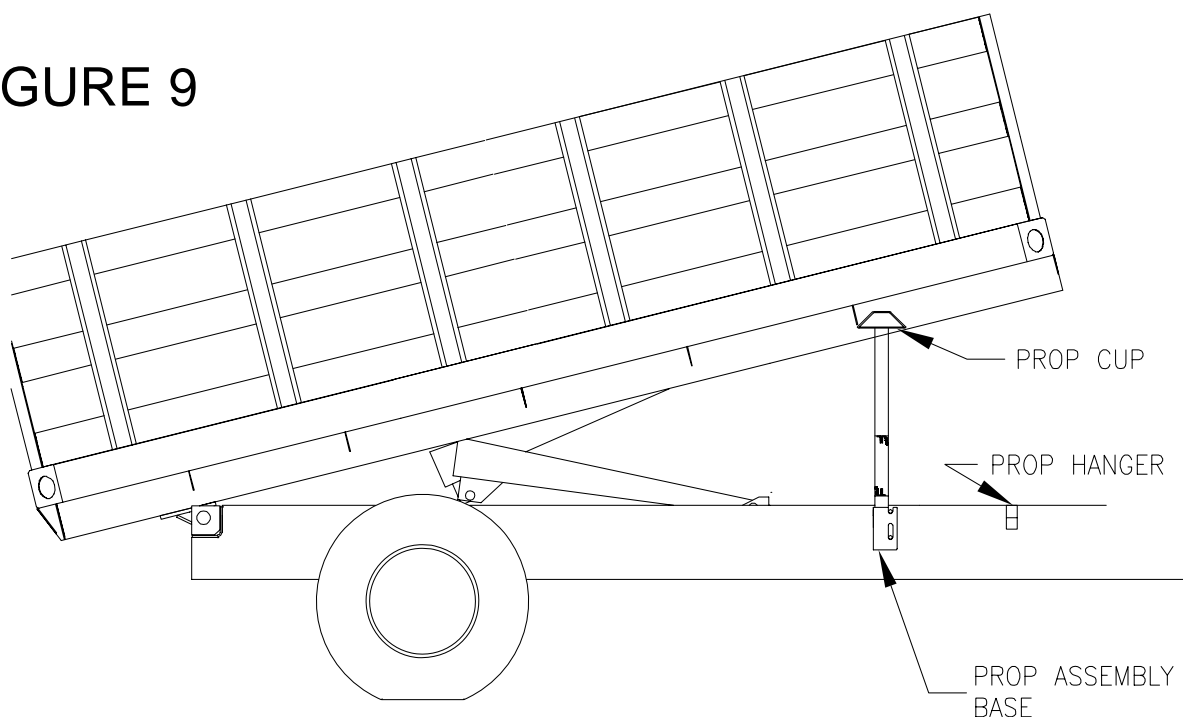

MOUNTING OF BODY PROP (FOR REFERENCE PURPOSES ONLY)

"LUBRICATION"

IMPORTANT: All grease fittings should be greased at least twice annually. Refer to Figure 10 for grease fitting locations.

IMPORTANT: Refer to installation and operation manual of the hydraulic system for hydraulic system lubrication instructions.

IMPORTANT: Several different types of pumps and hydraulic components are available to power the TB-16/TH-5550, TB-18/TH-650, or TB-20/TH-660 hoist. For installation and operation, refer to the installation and operation manual for your particular pump and hydraulic components.

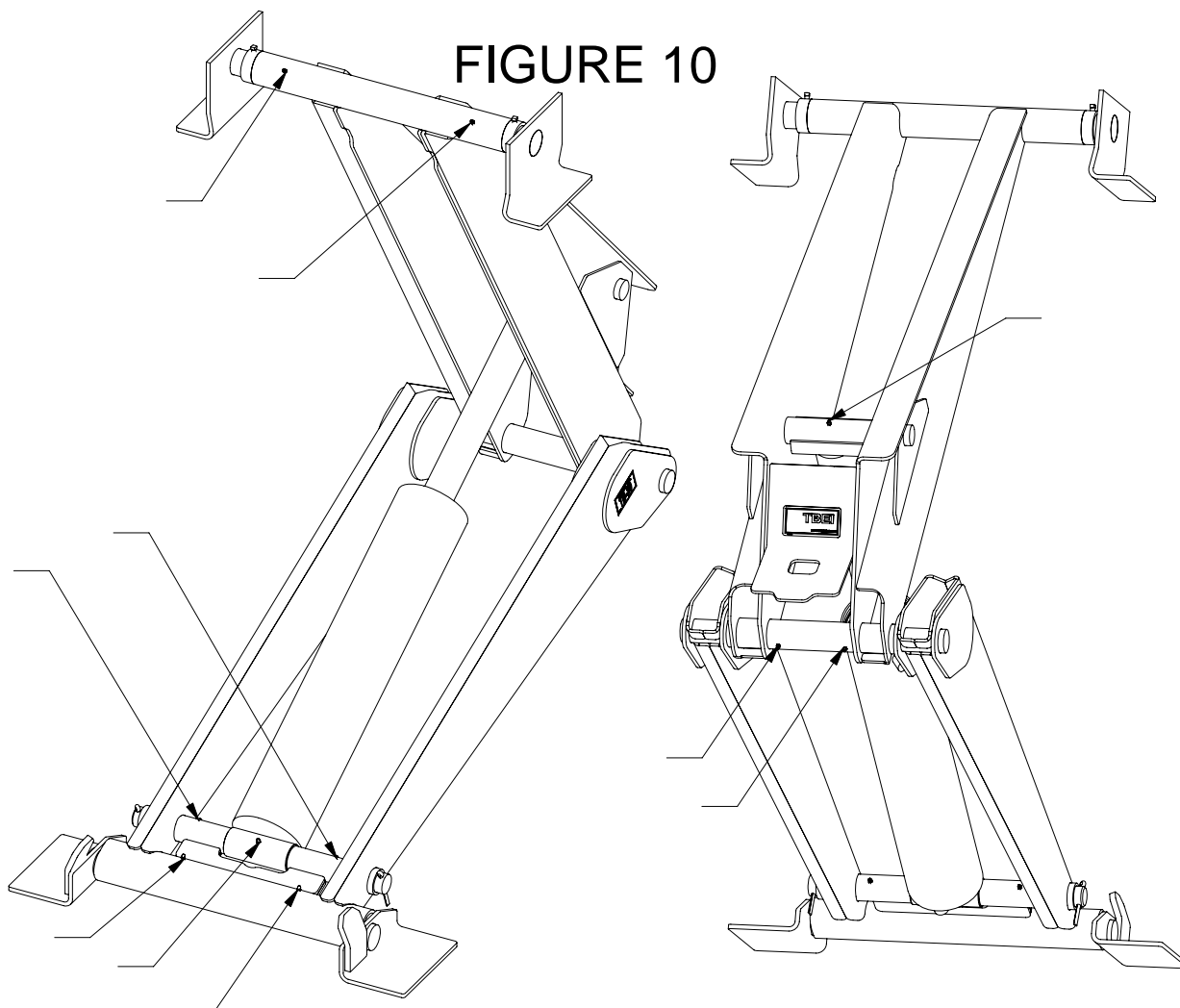

GREASE FITTING LOCATIONS
TB-16/TH-5550, TB-18/TH-650, or TB-20/TH-660

"DECAL LOCATION"

Two “**DANGER**” decals, as shown on this page are supplied with each hoist. These decals should be positioned on each side of the trailer body in a location where any person can easily read the decal without going under the body. The part number of the “**DANGER**” decal is 036200.

One “**WARNING**” decal, as shown on the next page is supplied with each hoist. This decal should be positioned on the driver’s side of the trailer near the front in a location where any person can easily read the decal without going under the body. The part number of the “**WARNING**” decal is 036204.

WARNING: Missing or damaged decals can cause incorrect or unsafe operation of the hoist, which can cause accidents, which may cause serious injury or death. If any decals are missing or damaged, they must be replaced.

To obtain replacement decals, contact your TBEI dealer or call 1-866-899-9045.



DANGER



1. STAY OUT FROM UNDER BODY WHEN HOIST IS OPERATING.
2. DURING DUMPING OPERATIONS, NO ONE MUST BE ALLOWED TO STAND IN OR MOVE THROUGH THE AREA WHERE BODY AND HOIST OPERATE OR INTO AN AREA WHERE AN UPSET LOAD MIGHT FALL.
3. CONTROLS MUST BE IN A SAFE LOCATION AND OPERATOR MUST REMAIN AT CONTROLS DURING THE DUMPING OPERATION. CONTROLS MUST BE PERMANENTLY LOCATED IN TRUCK CAB OR ANOTHER LOCATION WHERE IT IS NOT POSSIBLE TO BE UNDER BODY DURING DUMPING OPERATION.
4. NEVER LEAVE BODY RAISED OR PARTLY RAISED WHILE THE TRAILER IS UNATTENDED OR WHILE PERFORMING MAINTENANCE OR SERVICE UNDER BODY, UNLESS BODY IS BRACED TO PREVENT ACCIDENTAL LOWERING.
5. IF HOIST PUMP IS DIRECT ENGINE DRIVEN BY TRUCK, ALWAYS DISENGAGE DRIVE WHEN HOIST IS NOT IN USE OR WHEN MOVING LOAD.
6. DO NOT ATTEMPT TO RAISE A LOADED BODY WHEN THE TRUCK OR TRAILER IS ON UNLEVEL GROUND.
7. NEVER JERK OR SHOCK A RAISED BODY TO LOOSEN A STUCK LOAD.

036200

WARNING

Connecting the hoist to a hydraulic system with more pressure(psi) and flow(gpm) than is recommended by the hoist manufacturer, can cause the hoist to fail during the dumping of a load. This could lead to damage, serious injury, or death. " Be sure" you have the correct pressure and flow. If you do not know the recommended pressure and flow, consult the trailer manufacturer.

Adjusting the hydraulic pressure to more than the recommended setting may cause the hoist to fail during the dumping of the load. This could cause damage to the trailer, serious injury or death. Never adjust the pressure on your own. If the hydraulic pressure is in question consult the trailer manufacturer. Have only a qualified person set the hydraulic pressure.

Freeing a stuck load during dumping, with the body raised, by jerking or shocking the trailer, may cause damage to the trailer, serious injury, or death. Never drive forward or rearward and stop quickly with the load up or other wise shock the load. If a load is stuck in the body, lower the body , then free the load.

Being under a raised body can result in serious injury or death should the body unexpectedly descend. " Never" position yourself or allow others to position themselves under a " loaded" body. " Always" prop the " unloaded" body up using the body prop or body props supplied. " Remember" body props are to be used only on an " unloaded" body.

Attempting to dump a load on unlevel ground may cause the trailer to over turn, and can result in damage, serious injury or death. Always dump the load on ground that is level front to rear as well as level side to side.

036204



"OPERATION OF BODY PROP"

WARNING: Being under a raised body can result in serious injury or death should the body unexpectedly descend. **Never** position yourself or allow others to position themselves under a **loaded** body. **Always** prop the **unloaded** body up using the body prop or body props supplied. **Remember**, body props are to be used only on an **unloaded** body. When two props are provided, both props must be used.

Below is a step-by-step procedure for using the body prop.

1. Raise body to sufficient height and shut off all power.
2. Grasp prop handle at arms length and rotate prop upwards.
3. Swing prop up to vertical position and push down until prop locks in line with support bracket on the trailer body.
4. Using inside-the-cab controls, lower body slowly until prop contacts prop cup.

CAUTION: Do not power hoist down while on prop.

5. To lower prop for operation of trailer, "reverse" the procedure of the above four steps.

"OPERATION OF HOIST AND PUMP"

WARNING: Operating this hoist without first understanding the proper operation procedures can lead to serious injury or death. Always read and understand fully all operation manuals before using or operating this equipment.

WARNING: An operation manual for the hydraulic system has been included in this hoist's manual packet. If the hydraulic system used to power the TB-16/TH-5550, TB-18/TH-650, or TB-20/TH-660 hoist **WAS** supplied by TBEI, then the operation manual for the supplied hydraulic system **MUST BE** read and understood before operating this trailer.

WARNING: If the hydraulic system used to power the TB-16/TH-5550, TB-18/TH-650, or TB-20/TH-660 hoist was supplied by **SOMEONE OTHER** than TBEI, an operation manual for that hydraulic system **MUST BE** read and understood before operating this trailer.

WARNING: Being under a raised body can result in serious injury or death should the body unexpectedly descend. **Never** position yourself or allow others to position themselves under a **loaded** body. **Always** prop the **unloaded** body up using the body prop or body props supplied. **Remember**, body props are to be used only on an **unloaded** body.

DANGER:

1. Stay out from under body when hoist is operating.
2. During dumping operations, no one must be allowed to stand in or move through the area where the body and hoist operate or into an area where an upset load might fall.
3. Controls must be in a safe location and operator must remain at controls during the dumping operation. Controls must be permanently located in truck cab or another location where it is not possible to be under body during dumping operation.
4. **Never** leave body raised or partly raised while the trailer is unattended or while performing maintenance or service under body, unless body is braced to prevent accidental lowering.
5. If hoist pump is direct engine driven by truck, always disengage drive when hoist is not in use or when moving load.
6. **Do not** attempt to raise a loaded body when the truck or trailer is on un-level ground.
7. Never jerk or shock a raised body to loosen a stuck load.

WARNING: Freeing a stuck load during dumping, with the body raised, by jerking or shocking the trailer, may cause damage to the trailer, serious injury or death. **Never** drive forward or rearward and stop quickly with the load up or otherwise shock the load. If a load is stuck in the body, lower the body, then free the load.

WARNING: Attempting to dump a load on un-level ground may cause the trailer to over turn, and can result in damage, serious injury or death. **Always** dump the load on ground that is level front to rear as well as level side to side.

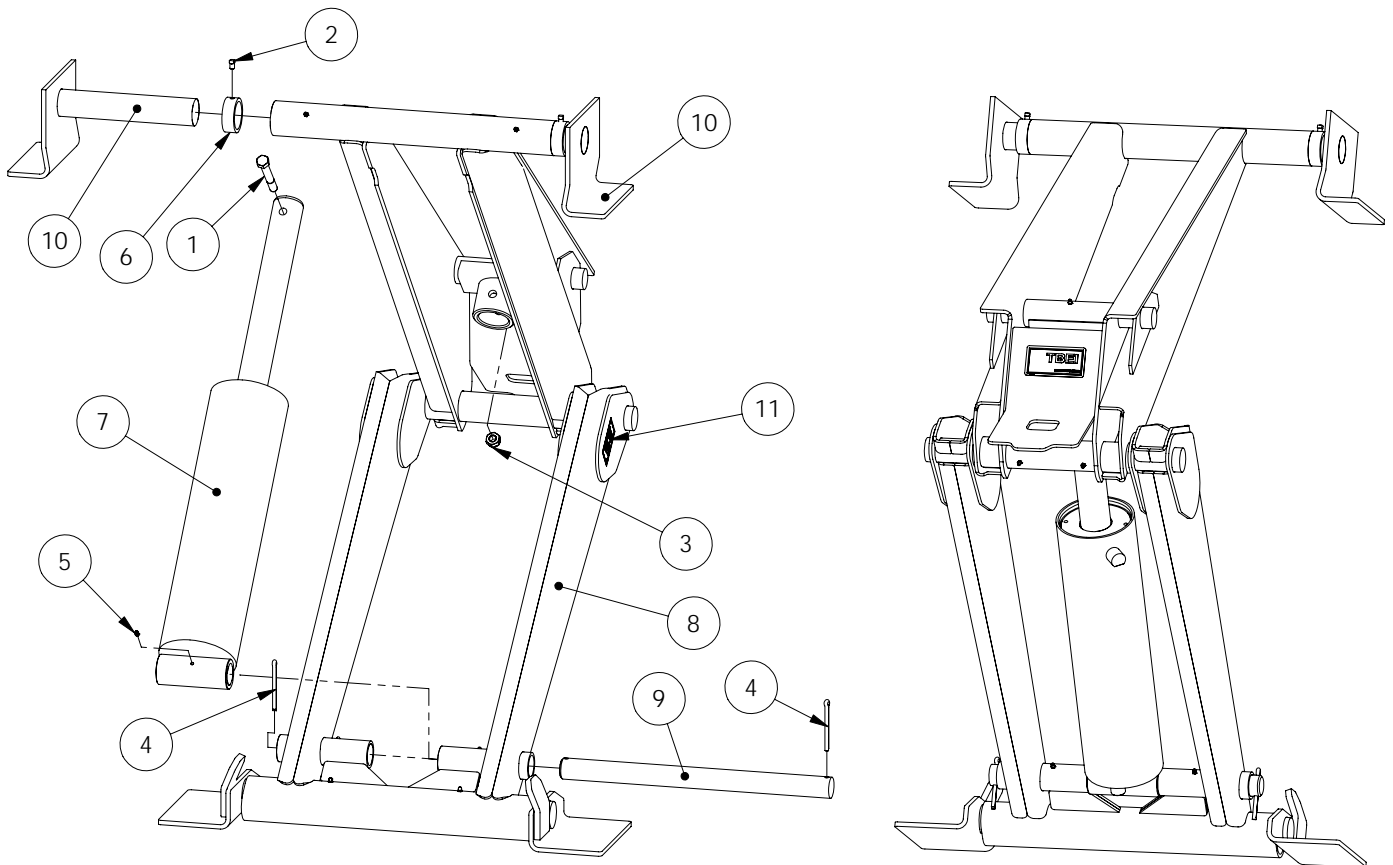

| ITEM | PART # | DESCRIPTION | QTY |
|------|---------|-------------------------------------|-----|
| 1 | 00 7396 | HHC SCREW, 5/8-11 X 4.5, GR. 8, PLT | 1 |
| 2 | 00 7452 | SET SCREW, 3/8-16 X 0.5 SQR HD, PLN | 2 |
| 3 | 00 7669 | NUT, 5/8-11 NYLOCK - NE, GR. 5 STL | 1 |
| 4 | 00 7959 | COTTER PIN 5/16" X 3 1/2" PLTD. | 2 |
| 5 | 00 8215 | FITTING, GREASE, THREAD FORMING | 10 |
| 6 | 03 3291 | LOCK RING | 2 |

| ITEM | PART # | DESCRIPTION | QTY |
|------|---------|-----------------------------|-----|
| 7 | 032588 | CYLINDER, 6 X 19, TH-5550 | 1 |
| 8 | 032701 | FRAME WELDMENT, TH-5550 | 1 |
| 9 | 032736 | CYLINDER PIN SHAFT, TH-5550 | 1 |
| 10 | 032743 | LIFTING SHAFT ASSY, TH-650 | 2 |
| 11 | 1200087 | DECAL, TB-16 | 1 |

MODEL TB-16 OR TH-5550 HOIST PARTS LIST
EFF. 05/26/2006

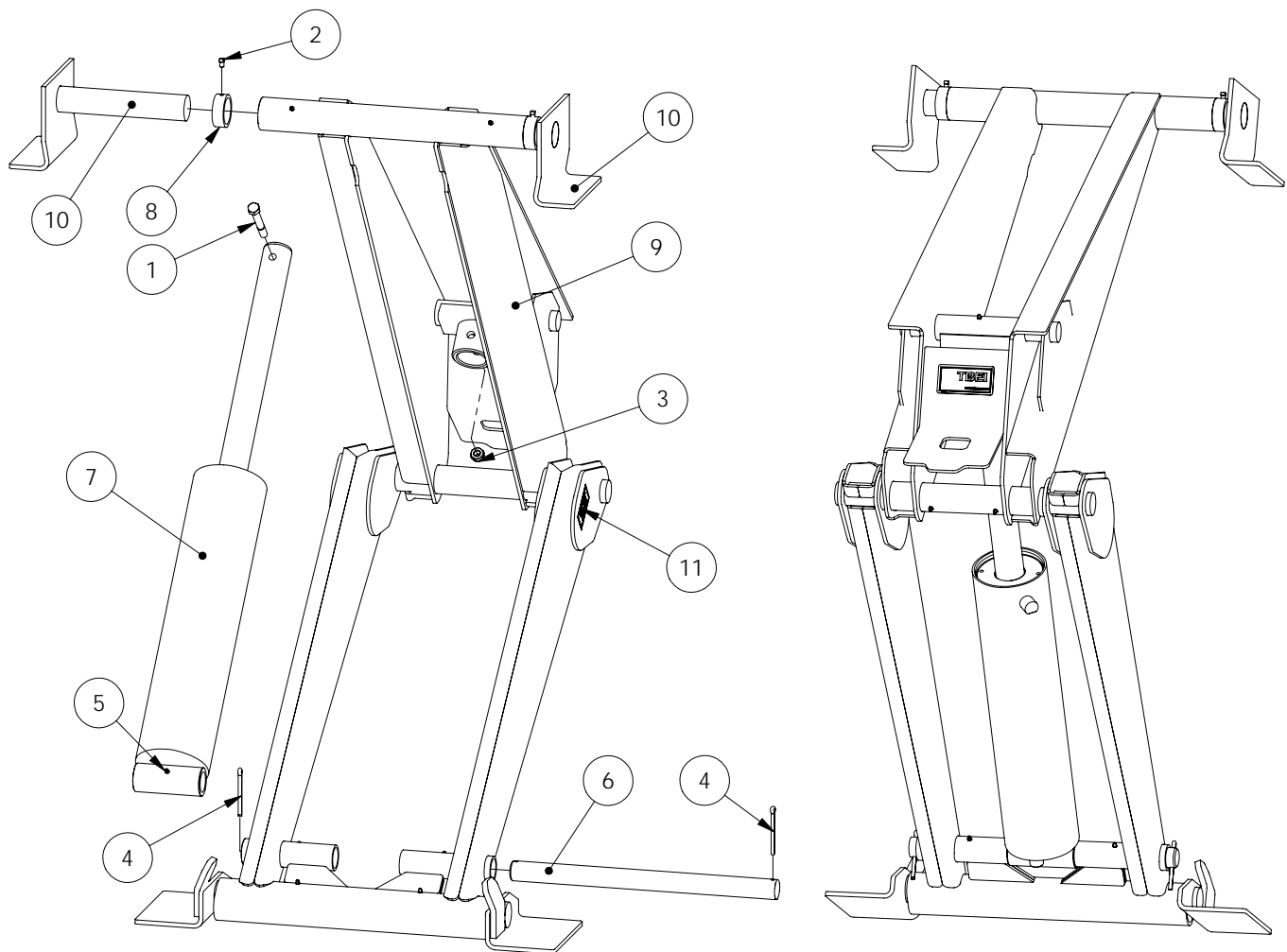

| ITEM | PART # | DESCRIPTION | QTY |
|------|---------|-------------------------------------|-----|
| 1 | 00 7396 | HHC SCREW, 5/8-11 X 4.5, GR. 8, PLT | 1 |
| 2 | 00 7452 | SET SCREW, 3/8-16 X 0.5 SQR HD, PLN | 2 |
| 3 | 00 7669 | NUT, 5/8-11 NYLOCK - NE, GR. 5 STL | 1 |
| 4 | 00 7959 | COTTER PIN 5/16" X 3 1/2" PLTD. | 2 |
| 5 | 00 8215 | FITTING, GREASE, THREAD FORMING | 10 |
| 6 | 03 0744 | CYLINDER PIN SHAFT, LR-28/26 | 1 |

| ITEM | PART # | DESCRIPTION | QTY |
|------|---------|----------------------------|-----|
| 7 | 03 2576 | CYLINDER, 6 X 23 | 1 |
| 8 | 03 3291 | LOCK RING | 2 |
| 9 | 032687 | FRAME WELDMNT, TH-650 | 1 |
| 10 | 032743 | LIFTING SHAFT ASSY, TH-650 | 2 |
| 11 | 1200088 | DECAL, TB-18 | 1 |

MODEL TB-18 OR TH-650 HOIST PARTS LIST
EFF. 05/26/2006

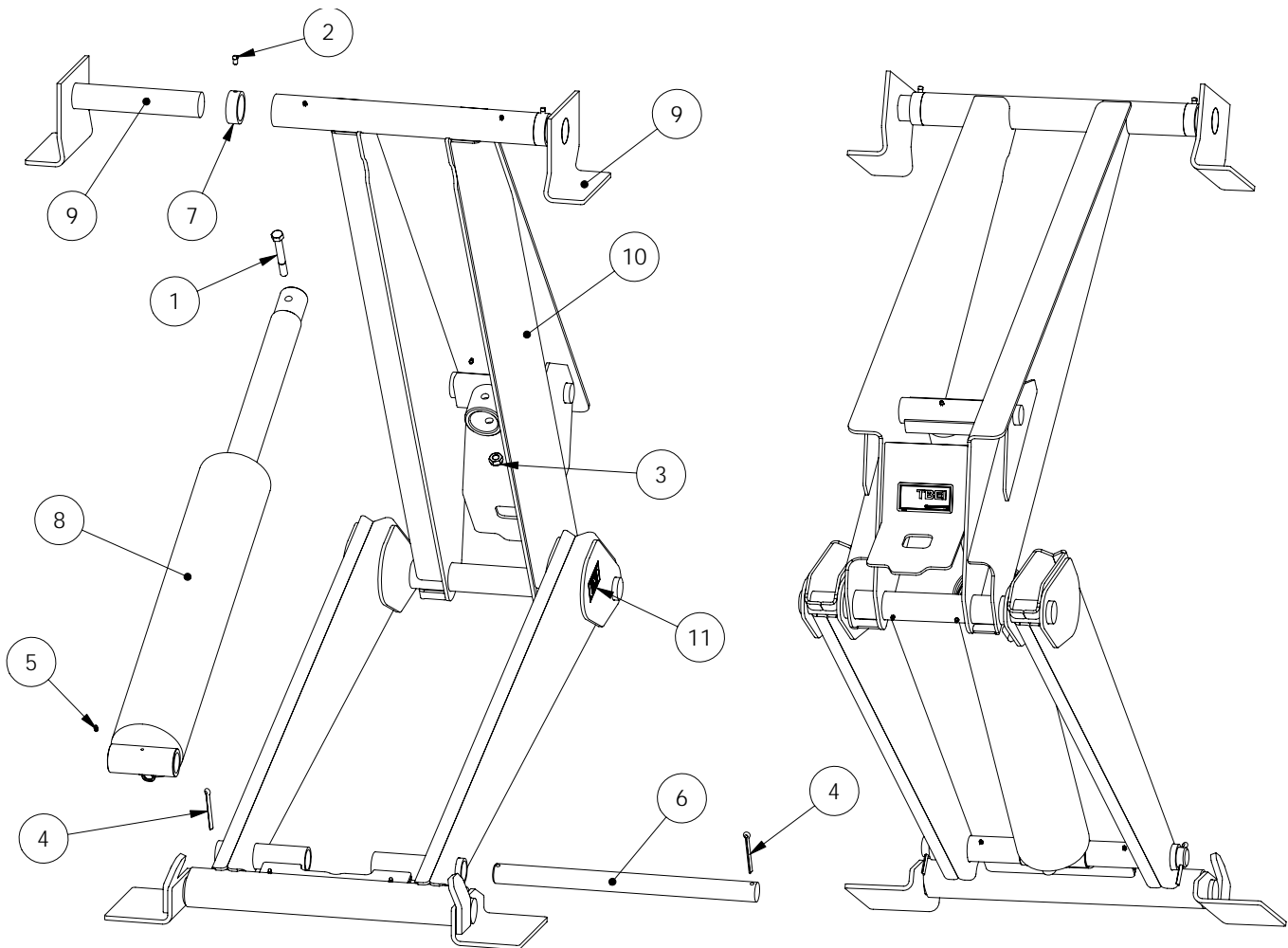

| ITEM | PART # | DESCRIPTION | QTY |
|------|---------|-------------------------------------|-----|
| 1 | 00 7396 | HHC SCREW, 5/8-11 X 4.5, GR. 8, PLT | 1 |
| 2 | 00 7452 | SET SCREW, 3/8-16 X 0.5 SQR HD, PLN | 2 |
| 3 | 00 7669 | NUT, 5/8-11 NYLOCK - NE, GR. 5 STL | 1 |
| 4 | 00 7959 | COTTER PIN 5/16" X 3 1/2" PLTD. | 2 |
| 5 | 00 8215 | FITTING, GREASE, THREAD FORMING | 10 |
| 6 | 03 0744 | CYLINDER PIN SHAFT, LR-28/26 | 1 |

| ITEM | PART # | DESCRIPTION | QTY |
|------|---------|----------------------------|-----|
| 7 | 03 3291 | LOCK RING | 2 |
| 8 | 032589 | CYLINDER, 6 X 29, TH-660 | 1 |
| 9 | 032743 | LIFTING SHAFT ASSY, TH-650 | 2 |
| 10 | 032750 | FRAME WELDMENT, TH-660 | 1 |
| 11 | 1200089 | DECAL, TB-20 | 1 |

MODEL TB-20 OR TH-660 HOIST PARTS LIST EFF. 05/26/2006